



ENERGY STAR® Program Requirements for Lamps (Light Bulbs)

Partner Commitments

Following are the terms of the ENERGY STAR Partnership Agreement as it pertains to the manufacture and labeling of ENERGY STAR qualified products. The ENERGY STAR Partner must adhere to the following partner commitments:

Qualifying Products

1. **Comply with current ENERGY STAR Eligibility Criteria**, which define performance requirements and test procedures for Lamps. A list of eligible products and their corresponding Eligibility Criteria can be found at www.energystar.gov/specifications.
2. **Prior to associating the ENERGY STAR name or mark with any product**, obtain written certification of ENERGY STAR qualification from a Certification Body recognized by EPA for Lamps. As part of this certification process, products must be tested in a laboratory recognized by EPA to perform Lamp testing. A list of EPA-recognized laboratories and Certification Bodies can be found at www.energystar.gov/testingandverification.

Using the ENERGY STAR Name and Marks

3. Comply with current ENERGY STAR Identity Guidelines, which define how the ENERGY STAR name and marks may be used. Partner is responsible for adhering to these guidelines and ensuring that its authorized representatives, such as advertising agencies, dealers, and distributors, are also in compliance. The ENERGY STAR Identity Guidelines are available at www.energystar.gov/logouse.
4. Use the ENERGY STAR name and marks only in association with qualified products. Partner may not refer to itself as an ENERGY STAR Partner unless at least one product is qualified and offered for sale in the U.S. and/or ENERGY STAR partner countries.
5. Provide clear and consistent labeling of ENERGY STAR qualified Lamps.
 - 5.1. The ENERGY STAR mark must be clearly displayed on the front or primary display panel of the product packaging, in product literature (i.e., user manuals, spec sheets, etc.) and on the manufacturer's Internet site where information about ENERGY STAR qualified models is displayed.

Verifying Ongoing Product Qualification

6. Participate in third-party verification testing through a Certification Body recognized by EPA for Lamps, providing full cooperation and timely responses. EPA/DOE may also, at its discretion, conduct tests on products that are referred to as ENERGY STAR qualified. These products may be obtained on the open market, or voluntarily supplied by Partner at the government's request.
7. Notify ENERGY STAR Certification Body recognized by EPA for Lamps, within 30 days, if the designated suppliers of any certified private labeled Lamps change to a new supplier.

Providing Information to EPA

8. Provide unit shipment data or other market indicators to EPA annually to assist with creation of ENERGY STAR market penetration estimates, as follows:

- 8.1. Partner must submit the total number of ENERGY STAR qualified Lamps shipped in the calendar year or an equivalent measurement as agreed to in advance by EPA and Partner. Partner shall exclude shipments to organizations that rebrand and resell the shipments (unaffiliated private labelers).
- 8.2. Partner must provide unit shipment data segmented by meaningful product characteristics (e.g., type, capacity, presence of additional functions) as prescribed by EPA.
- 8.3. Partner must submit unit shipment data for each calendar year to EPA or an EPA-authorized third party, preferably in electronic format, no later than March 1 of the following year.

Submitted unit shipment data will be used by EPA only for program evaluation purposes and will be closely controlled. If requested under the Freedom of Information Act (FOIA), EPA will argue that the data is exempt. Any information used will be masked by EPA so as to protect the confidentiality of the Partner.

9. Report to EPA any attempts by recognized laboratories or Certification Bodies (CBs) to influence testing or certification results or to engage in discriminatory practices.
10. Notify EPA of a change in the designated responsible party or contacts within 30 days using the My ENERGY STAR Account tool (MESA) available at www.energystar.gov/mesa.

Performance for Special Distinction

In order to receive additional recognition and/or support from EPA for its efforts within the Partnership, the ENERGY STAR Partner may consider the following voluntary measures, and should keep EPA informed on the progress of these efforts:

- Provide quarterly, written updates to EPA as to the efforts undertaken by Partner to increase availability of ENERGY STAR qualified products, and to promote awareness of ENERGY STAR and its message.
- Consider energy efficiency improvements in company facilities and pursue benchmarking buildings through the ENERGY STAR Buildings program.
- Purchase ENERGY STAR qualified products. Revise the company purchasing or procurement specifications to include ENERGY STAR. Provide procurement officials' contact information to EPA for periodic updates and coordination. Circulate general ENERGY STAR qualified product information to employees for use when purchasing products for their homes.
- Feature the ENERGY STAR mark(s) on Partner website and other promotional materials. If information concerning ENERGY STAR is provided on the Partner website as specified by the ENERGY STAR Web Linking Policy (available in the Partner Resources section of the ENERGY STAR website), EPA may provide links where appropriate to the Partner website.
- Ensure the power management feature is enabled on all ENERGY STAR qualified displays and computers in use in company facilities, particularly upon installation and after service is performed.
- Provide general information about the ENERGY STAR program to employees whose jobs are relevant to the development, marketing, sales, and service of current ENERGY STAR qualified products.
- Provide a simple plan to EPA outlining specific measures Partner plans to undertake beyond the program requirements listed above. By doing so, EPA may be able to coordinate, and communicate Partner's activities, provide an EPA representative, or include news about the event in the ENERGY STAR newsletter, on the ENERGY STAR website, etc. The plan may be as simple as providing a list of planned activities or milestones of which Partner would like EPA to be aware. For example, activities may include: (1) increasing the availability of ENERGY STAR qualified products by converting the entire product line within two years to meet ENERGY STAR guidelines; (2) demonstrating the economic and environmental benefits of energy efficiency through special in-store displays twice a year; (3) providing information to users (via the website and user's manual) about energy-saving features and operating characteristics of ENERGY STAR qualified products; and (4) building awareness of the ENERGY STAR Partnership and brand identity by collaborating with EPA on one print advertorial and one live press event.

- Join EPA's SmartWay Transport Partnership to improve the environmental performance of the company's shipping operations. The SmartWay Transport Partnership works with freight carriers, shippers, and other stakeholders in the goods movement industry to reduce fuel consumption, greenhouse gases, and air pollution. For more information on SmartWay, visit www.epa.gov/smartway.
- Join EPA's Green Power Partnership. EPA's Green Power Partnership encourages organizations to buy green power as a way to reduce the environmental impacts associated with traditional fossil fuel-based electricity use. The partnership includes a diverse set of organizations including Fortune 500 companies, small and medium businesses, government institutions as well as a growing number of colleges and universities. For more information on Green Power, visit www.epa.gov/greenpower.



ENERGY STAR® Program Requirements Product Specification for Lamps (Light Bulbs)

Eligibility Criteria Version 2.0

Following is the Version 2.0 product specification for ENERGY STAR certified Lamps. A product shall meet all of the identified criteria if it is to earn the ENERGY STAR.

To certify a lamp for ENERGY STAR, first determine which requirements in this document are applicable to the specific lamp. ENERGY STAR requirements are specific to lamps classified by the program as omnidirectional, directional, or decorative. This specification is generally organized by the requirements, not by lamp type or by light source technology. Partners are advised to review each section, and take note of exceptions where specific performance criteria need not be evaluated.

1. SPECIFICATION SCOPE & LAMP CLASSIFICATION

1.1. Included Products

The ENERGY STAR Lamps specification (“this specification”) scope includes the lamp types intended to replace incandescent lamps as outlined in Table 1. The scope of this specification is limited to lamps with:

- Integrated ballasts and drivers intended to be connected to the electric power grid with the following ANSI standard base types: E26, E26d, E17, E11, E12, G4, G9, GU10, GU24, GU5.3, and GX5.3; and
- Rated nominal operating voltages of 120, 240 or 277 VAC, or 12 or 24 VAC or VDC.

Table 1: Specification Scope and Classification

Lamp Purpose and Performance Description	ANSI Standard Lamp Shape ¹	Non-Standard Lamp Form Factor
Omnidirectional – Lamps intended for general purpose that meet applicable omnidirectional performance requirements in this specification.	A, BT, P, PS, S and T	Self-ballasted compact fluorescent lamps (CFLs) intended to replace ANSI standard incandescent lamps that do not meet Lamp Shape Dimension requirements. The following self-ballasted compact fluorescent lamps are included: <ul style="list-style-type: none"> • Bare spiral • Bare mini-spiral • Bare twin tube • Bare triple tube • Bare quadruple tube • Covered CFLs • Covered CFLs with reflectors • Induction-driven electrodeless fluorescent lamp
Decorative – Lamps of common decorative shapes meeting applicable decorative performance requirements in this specification.	B, BA, C, CA, DC, F, G, and ST	
Directional – Lamps meeting applicable directional performance requirements in this specification.	R, BR, ER, MR, MRX and PAR	

1.2. Excluded Products:

- Lamps, other than MR and halogen capsule replacements, that operate only on an external (i.e., not integral to the lamp) ballast, driver or transformer, e.g., pin-based fluorescent lamps (linear and compact) or their solid-state replacements.
- LED lamps intended to replace linear fluorescent lamps.
- LED lamps intended to replace pin-based compact fluorescent lamps.
- LED lamps intended to replace high-intensity discharge lamps.
- Lamps powered by an internal power source (e.g., solar-powered cell).

¹ Standard form factor lamps must meet the ANSI standard lamp type dimensional requirements in the specification and may claim wattage and ANSI lamp type equivalency. All solid-state lamps must meet standard lamp dimensional requirements.

- Lamps incorporating power-consuming features in the on or off state which are not related to control of illumination (e.g., audio functions, air fresheners, or cameras).
- Lamp technologies lacking applicable industry standardized methods of measurement.
- Lamps with bases not covered in ANSI standards.
- Zhaga compliant LED light engines.
- LED lamps that could be mistaken for general purpose A-lamp replacements (e.g., a G18.5 or G19 lamp), that do not meet the omnidirectional luminous intensity distribution requirements. This would include decorative lamps that fall within the minimum and maximum diameter of common A-shape lamps (between 41mm and 78mm) with the exception of G16.5 and G25 lamps.

2. EFFECTIVE DATE

The ENERGY STAR Lamps Version 2.0 specification shall take effect January 2, 2017. To qualify for ENERGY STAR, a product model shall meet the ENERGY STAR specification in effect on its date of manufacture. The date of manufacture is specific to each unit and is the exact date on which a unit is considered to be completely assembled.

3. FUTURE SPECIFICATION REVISIONS

EPA reserves the right to change this specification should technological and/or market changes affect its usefulness to consumers, industry, or the environment. In keeping with current policy, revisions to the specification are arrived at through stakeholder discussions. In the event of a specification revision, please note that ENERGY STAR certification is not automatically granted for the life of a product model.

While this document currently refers to industry standards and test procedures for fluorescent and solid-state lighting sources, as new technologies emerge that have equal or better performance to the levels proposed here, consistent with a technology neutral approach, EPA may amend the program requirements by adding additional requirements, methods of measurement and reference documents.

3.1. Considerations for Future Revisions

EPA is committed to continuing to develop performance levels for lamps that account for special features and functionality that benefit consumers. EPA and the U. S. Department of Energy (DOE) actively monitor the activities of lighting standards working groups and regulatory activities that may impact ENERGY STAR specifications. EPA will continue to monitor the market and work with stakeholders to explore and refine methods for evaluating the below features, test methods, and performance criteria.

- 3.1.1.** Luminous intensity distribution requirements for all lamp types
- 3.1.2.** Enhanced requirements for dimmable lamps
- 3.1.3.** Zhaga compliant LED light engines
- 3.1.4.** Industry and DOE test methods in development
- 3.1.5.** Transient Protection
- 3.1.6.** CRI as an allowable product variation
- 3.1.7.** Standby power reduction
- 3.1.8.** Additional lamp shapes and base types.
- 3.1.9.** Product variations.

TABLE OF CONTENTS

1. Specification Scope & Lamp Classification	1
1.1. Included Products	1
1.2. Excluded Products:	1
2. Effective Date	2
3. Future Specification Revisions	2
3.1. Considerations for Future Revisions	2
4. Definitions	5
5. Test Criteria	8
5.1. Testing Color Tunable Lamps	8
6. United States Federal Regulations	9
6.1. U.S. Department of Energy (DOE)	9
6.2. U.S. Federal Trade Commission (FTC)	9
6.3. U.S. Federal Communications Commission (FCC)	9
7. Product Certification	9
7.1. Product Variations	9
7.2. Solid-State Lumen Maintenance Performance Data	10
7.3. Temperature Measurements	10
7.4. Photographs.....	10
7.5. Significant Digits and Rounding.....	10
8. Methods of Measurement and Reference Documents	11
9. Photometric Performance	12
9.1. Luminous Efficacy: All Lamps	12
9.2. Light Output	13
9.3. Elevated Temperature Light Output Ratio: All Directional Lamps	14
9.4. Center Beam Intensity: PAR, MR and MRX Lamps	14
9.5. Luminous Intensity Distribution: ANSI Standard Omnidirectional and Decorative.....	15
9.6. Correlated Color Temperature (CCT): All Lamps	15
9.7. Color Rendering: All Lamps	16
9.8. Color Maintenance: All Solid-State Lamps	16
9.9. Color Angular Uniformity: Solid-State Directional Lamps	16
10. Lumen Maintenance and Rated Life	17
10.1. Lumen Maintenance: All Lamps	17
10.2. Rated Life: All Lamps	19
10.3. Rapid Cycle Stress Test: Compact Fluorescent Lamps	20
11. Electrical Performance Requirements	21
11.1. Electrical Safety: All Lamps	21
11.2. Power Factor: All Lamps.....	21
11.3. Frequency: All Lamps	21
11.4. Start Time: All Lamps	22
11.5. Run-Up Time: All Compact Fluorescent Lamps	22
11.6. Transient Protection: All Line Voltage Lamps	22
11.7. Standby Power Consumption: All Lamps	22
12. Controls Requirements: Lamps employing any control mechanism	23
12.1. Dimming Performance: All Lamps Marketed as Dimmable	23
12.2. Maximum Light Output:.....	23
12.3. Minimum Light Output:	23
12.4. Flicker:.....	24
12.5. Audible Noise:.....	24
12.6. Products with Connected Functionality – Optional	24
12.7. Connected Product Criteria:	24
12.8. Open Access.....	24
12.9. Energy Consumption Reporting	25

12.10. Operational Status Reporting	25
12.11. Remote Management	25
12.12. Information to Consumers	25
13. Lamp Toxics Reduction	26
13.1. Lamp Toxics Reduction: All Lamps	26
14. Dimensional Requirements	27
14.1. Lamp Shape Dimensions: All ANSI Standard Lamps and GU-24 base Solid-state Lamps	27
(Exemption: Non-Standard Lamps).....	27
15. Lamp Labeling, Packaging & Warranty Requirements	27
15.1. Lamp Labeling: All Lamps.....	27
15.2. Lamp Packaging: All Lamps except as Noted	28
15.3. Warranty: All Lamps.....	29
Appendix A-1: LUMINOUS Intensity Distribution Diagram for Omnidirectional Lamp	30
Appendix A-2: LUMINOUS Intensity Distribution Diagram for Decorative Lamp	31
Appendix B: CERTIFICATION Milestones for Rated Life Testing	32

4. DEFINITIONS

Active Mode: The state where the energy using product is connected to a mains power source and the primary light-producing function is activated. (Adapted from IEC 62301 Edition 2.0 2011-01)

ANSI: American National Standards Institute.

ASTM: American Society for Testing of Materials.

Beam Angle: The angle, in degrees, between the two opposite directions in which the average intensity is 50% of the center beam intensity as measured in at least two rotational planes, 90° from each other, around and through the beam axis. (ANSI C78.379-2006)

CFL: See Compact Fluorescent Lamp.

CIE: Commission Internationale de l'Eclairage. (International Commission on Illumination)

Color Rendering: Effect of an illuminant on the color appearance of objects by conscious or subconscious comparison with their color appearance under a reference illuminant. (CIE 17.4, ANSI/IES RP-16-10)

Color Rendering Index (CRI): The measured degree of color shift objects undergo when illuminated by a light source as compared with the color of those same objects when illuminated by a reference source of comparable color temperature. (10CFR430.2)

Color Tunable Lamp: For the purpose of this specification, these products allow the end user to alter the color appearance of the light generated by the lamp, including any of the following features:

Color Shifting Dimmable (aka Dim-to-Warm): A feature where CCT is automatically reduced as the product is dimmed, to simulate the behavior of incandescent lamps.

Full-Color-Tunable: A feature allowing the end user to adjust the light output to create white or colored light. This tuning must include white light that is capable of meeting the specification's color requirements, and can alter the color appearance along the black body curve, and also extend to colors beyond the ANSI defined correlated color temperature ranges (e.g., 2700K and 6500K) outside of the seven step MacAdam ellipse or the ANSI quadrangles.

White-Tunable: A feature allowing the end user to adjust the light output over a range of CCTs. This tuning must include white light that is capable of meeting the specification's color requirements along the black body curve.

Compact Fluorescent Lamp (CFL): A fluorescent lamp with a small diameter glass tube (T5 or less) that is folded, bent, or bridged to create a long discharge path in a small volume. The lamp design generally includes an amalgam and a cold chamber, or a cold spot to control the mercury vapor pressure and light output (ANSI/IES RP-16-10). For purposes of this specification, compact fluorescent lamps include integral electronic ballasts and are equipped with an ANSI standard base.

Connected Lamp: An ENERGY STAR eligible connected lamp includes elements (hardware and software or firmware) or instructions required to enable communication in response to consumer-authorized energy or performance related commands and complies with all requirements for connected lamps in the specification. These elements may reside inside or outside of the base lamp.

Correlated Color Temperature (CCT): The absolute temperature of a blackbody whose chromaticity most nearly resembles that of the light source. (10CFR430.2)

Covered Lamp: A lamp with an integral ballast or driver and a translucent envelope over the light source(s). See Envelope.

Decorative Lamp: A lamp with a candle-like or globe shape envelope including shapes B, BA, C, CA, DC, G and F as defined in ANSI C79.1-2002. For purposes of this specification, lamps with candelabra bases and compact fluorescent lamps with purely decorative outer envelopes including those emulating A shape incandescent bulbs may be tested and evaluated as decorative lamps.

Device Under Test (DUT): An LED lamp under test. (Adapted from IES TM-28-14)

Dimmable Lamp: A lamp that is capable of producing varying levels of light when paired with a suitable control. For the purposes of this specification, the lamp must be capable of reducing light output to 20% (or lower) when paired with a control or dimmer while meeting the associated performance requirements in the specification.

Directional Lamp: ANSI standard PAR and MR lamps having at least 80% light output with a solid angle of π steradians, corresponding to a cone with an angle of 120°, self-ballasted compact fluorescent forms that utilize a reflector, and ANSI standard R, BR and ER shapes.

Envelope: A transparent or translucent enclosure over a light source. An envelope can also consist of a reflector with integral front cover. (Adapted from ANSI C78.357-2010)

FTC: United States Federal Trade Commission.

Field Angle: The angle between the two directions for which the intensity is 10% of the maximum intensity as measured in a plane through the nominal beam centerline. (ANSI/IES RP-16-10)

Flicker: The impression of unsteadiness of visual perception induced by a light stimulus whose luminance or spectral distribution fluctuates with time. (CIE 17.443 e-ILV) This term is for a static observer in a static environment.

Flicker Index: A measure of the cyclic variation in output of a light source taking into account the waveform of the light output. It is the ratio of the area under the light output curve that is above the average light output level to the total area under the light output curve for a single cycle. (ANSI/IES RP-16-10)

GU24 Based Integrated Lamp: A lamp unit that integrates the light source and its ballast or driver. It does not include any replaceable or interchangeable parts, and utilizes the ANSI standardized GU24-base type.

IEC: International Electrotechnical Commission.

IES: Illuminating Engineering Society.

Induction Driven Electrodeless Fluorescent Lamp: A fluorescent lamp that uses electromagnetic induction to generate a discharge current, forming a closed loop inside the tube structure which excites internal gases and converts this into visible

light through phosphor. For purposes of this specification, these lamps include integral electronic ballasts and are equipped with an ANSI standard base, and are also referred to as “induction lamps”.

Input Power: The power draw in watts of a ballast or driver and a light source system operating in a normal mode.

Integrated LED Lamp: An integrated assembly comprised of LED packages (components) or LED arrays (modules), LED driver, ANSI standard base and other optical, thermal, mechanical and electrical components. The device is intended to connect directly to the branch circuit through a corresponding ANSI standard lamp-holder (socket). (ANSI/IES RP-16-10)

Labeled Wattage: The highest wattage marked on the lamp and/or lamp packaging. (US DOE)

Lamp: A generic term for a man-made source created to produce optical radiation. By extension, the term is also used to denote sources that radiate in regions of the spectrum adjacent to the visible. (ANSI/IES RP-16-10)

LED: See Light-emitting Diode.

LED Array or Module: An assembly of LED packages (components) or dies on a printed circuit board or substrate, possibly with optical elements and additional thermal, mechanical, and electrical interfaces that are intended to connect to the load side of a LED driver. Power source and ANSI standard base are not incorporated into the device. The device cannot be connected directly to the branch circuit. (ANSI/IES RP-16-10)

LED Driver Case Temperature Measurement Point (TMP_C): A location on an LED driver case, designated by its manufacturer, which will have the highest temperature of any point on the driver case during normal operation.

LED Package: An assembly of one or more LED dies that includes wire bond or other type of electrical connections, possibly with an optical element and thermal, mechanical, and electrical interfaces. Power source and ANSI standardized base are not incorporated into the device. The device cannot be connected directly to the branch circuit. (ANSI/IES RP-16-10)

LED Temperature Measurement Point (TMP_{LED}): A location on an LED package/module/array, designated by its manufacturer, which provides a surrogate temperature measurement location for the actual LED junction. The TMP_{LED} may be a solder joint at the board attachment site, a point on the LED package case, or a location on the board of an LED module or array.

Light-emitting Diode (LED): A p-n junction solid-state device of which the radiated output, either in the infrared region, the visible region, or the ultraviolet region, is a function of the physical construction, material used, and exciting current of the device. (10CFR430.2)

Lumen Maintenance: The lumen output measured at a given time in the life of the lamp and expressed as a percentage of the measured initial lumen output, respectively. Lumen maintenance is the converse of lumen depreciation.

Lumens per Watt (lm/W): The quotient of the total luminous flux emitted by the total light source power input. It is expressed in lm/W. (Adapted from ANSI/IES RP-16-10: “Luminous Efficacy of a Source of Light”)

MacAdam Color Ellipse: A space around a chromaticity coordinate that sets the boundary at which a given percentage of people are able to determine that two colors, one with chromaticity coordinates at the center of the ellipse, and one with chromaticity coordinates on the ellipse, are just noticeably different. (Adapted from IES Handbook 10th Edition)

Measured value: The directly measured value from testing equipment for a given unit under test.

Multi-power Lamp: A lamp designed to produce multiple discrete light levels when inserted into a lamp socket controlled by a switching mechanism and is designated on the lamp packaging as being a multi-power lamp, e.g., 3-way lamp.

NEMA: National Electrical Manufacturers Association.

NRTL: Nationally Recognized Testing Laboratory as recognized by OSHA’s NRTL Program, which is a part of OSHA’s Directorate of Technical Support.

Off Mode: The state where the energy using product is connected to a mains power source and is not providing any standby mode, network mode, or active mode function. (IEC 62301 Edition 2.0 2011-01)

Omnidirectional Lamp: A general service replacement lamp with an ANSI standard base that emits the majority of light produced in an even distribution. See Luminous Intensity Distribution requirement for omnidirectional lamps. These lamps can be standard; having an ANSI standard lamp shape of A, BT, P, PS, S or T, or non-standard, such as a self-ballasted compact fluorescent that utilizes a bare spiral.

OSHA: Occupational Safety & Health Administration.

Percent Flicker: A relative measure of the cyclic variation in output of a light source (percent modulation). It is given by the expression $100(A-B)/(A+B)$, where A is the maximum and B is the minimum output during a cycle. (IES RP-16-10)

Periodic Frequency: The frequency at which the entire periodic flicker waveform pattern repeats.

Power Factor: The input power in watts divided by the product of RMS input voltage and RMS input current of a ballast or driver.

Rated Lumen Maintenance Life (L_p): The elapsed operating time over which the LED light source will maintain the percentage, p, of its initial light output, e.g., L₇₀ (hours): time to 70% lumen maintenance. (IES LM-80-08)

Rated Wattage: The wattage marked on the lamp (referred to as “labeled wattage” by DOE). (10 CFR 430 Appendix W to Subpart B)

Referenced Incandescent Lamp: A traditional incandescent lamp that predates the federal efficiency standards in the 2007 Energy Independence and Security Act.

Reflector: A device used to redirect the flux from a source primarily by the process of reflection. (IES RP-16-10)

Reported value: The value reported for purposes of compliance with DOE (referred to as “represented value” by DOE) and/or ENERGY STAR requirements according to the criteria in each applicable section.

Run-up Time: The time between the application of power to the device and the time when the light output first reaches a specified percentage of stable light output, i.e., 80%, 90%, etc.

Secondary Optics: Materials modifying the distribution of light from, but not integral to a light source, including but not limited to lamp envelopes, reflectors, and total internal reflection optics.

Solid-State Lighting (SSL): The term “solid-state” refers to the fact that light is emitted from a material by a semiconducting process of electron transition from a conduction band to valence band process whether or not the wavelength of this light is converted by additional components.

Standardized Color Ellipse: A MacAdam color ellipse defined by center chromaticity coordinates (CIE x, y) and a measure of certainty for detecting a color difference specified in standard deviation units called steps. (ANSI C78.376-2001)

Standby Mode: The condition in which the energy-using product is connected to a main power source; and offers one or more of the following user-oriented or protective functions: to facilitate the activation or deactivation of other functions (including active mode) by remote switch (including remote control), internal sensor, or timer; or continuous functions, including information or status displays (including clocks) or sensor-based functions. (US DOE)

Stroboscopic Effect: The appearance of multiple, discrete images of moving objects as a result of temporally unstable illumination. The effect may also change the appearance of the objects in their motion. (IEEE Std 1789™-2015) This term is for a static observer in a non-static environment.

Temporal Light Artifact (TLA): An undesired change in visual perception induced by a light stimulus whose luminance or spectral distribution fluctuates with time for an observer in a certain environment. Depending on the details of the fluctuations, TLA consists of flicker and/or stroboscopic effect. (NEMA TLAs-2015)

TMP_C: See LED Driver Case Temperature Measurement Point.

TMP_{LED}: See LED Temperature Measurement Point.

5. TEST CRITERIA

Performance requirements in this specification are determined in part by referencing the performance data of a traditional incandescent lamp (the “referenced incandescent lamp”). Referenced incandescent lamp performance data shall include shape designations appearing in ANSI C79.1-2002 (e.g., A, C, G, MR, PAR etc.), lamp diameter in eighths of an inch (e.g., MR-16 diameter = 16 eighths of an inch), nominal wattage, and beam angle for directional types.

Performance requirements in this specification are also determined by the replacement lamps’ type and form factor per [Table 1](#). Lamps claiming equivalency with an ANSI lamp shape on the lamp, its base or packaging, product literature or point-of-purchase materials, either printed or electronic, shall meet all requirements detailed in this specification for ANSI standard lamps.

When testing lamps, the methods of measurement identified for each performance characteristic in the “Methods of Measurement and/or Reference Documents” column of the performance requirements tables presented within this specification shall be used along with the sampling requirements in the calculation of reported values to determine ENERGY STAR certification.

All tests shall be conducted with the lamp connected to a supply circuit of rated frequency. For lamps with multiple operating voltages, the lamp shall be operated at 120 volts throughout testing. If the lamp is not rated for 120 volts, it shall be operated at the highest rated voltage.

For dimmable or multi-power lamps, measurements shall be taken at the highest wattage setting listed for the model, unless otherwise specified. This includes color shifting dimmable (dim-to-warm) lamps unless the lamp can also be tuned to a different chromaticity at full output.

IES LM-65-14 and IES LM-66-14 are applicable to both hot and cold cathode lamps, and induction lamps.

5.1. Testing Color Tunable Lamps

The requirements of this section do not apply to products that only have color shifting dimmable (dim-to-warm) functionality because they are only evaluated at the highest wattage setting.

For full-color-tunable and white-tunable lamps:

- All tests and evaluations included in this specification shall be performed at the most consumptive white light setting covered by this specification²; and
- Watts, lumens, chromaticity, and CRI shall be tested and reported for default and most consumptive white light setting covered by this specification.

In order to facilitate compliance testing, the partner shall provide detailed instructions for the control settings or control signals (as applicable) for reaching the default, and most consumptive white light modes as applicable.

² 2200K and 2500K nominal CCTs are only applicable to filament style lamps.

6. UNITED STATES FEDERAL REGULATIONS

Various U.S. federal regulations (U.S laws) may apply to lamps covered under the scope of this specification. As a reminder, EPA has included references to the rules and/or rule-making. Partners should consult the appropriate federal agencies regarding compliance with the regulations.

6.1. U.S. Department of Energy (DOE)

The scope of this specification includes bare and covered medium base compact fluorescent lamps which are regulated by the U.S. Department of Energy (DOE). This specification includes references to the Code of Federal Regulations (CFR), such as CFR Title 10 Part 429 and Part 430, as guidance, highlighting efforts by EPA and DOE to align the testing requirements where there is overlap in scope. Any DOE issued guidance for medium base CFLs must be used in determining ratings. (<http://www1.eere.energy.gov/guidance/default.aspx?pid=2&spid=1>).

For information on the Code of Federal Regulations (CFR), including CFR Title 10 Parts 429 and 430, see DOE website, www.eere.energy.gov/buildings.

6.2. U.S. Federal Trade Commission (FTC)

CFR Title 16 Part 305, see FTC website www.ftc.gov/energy for additional information.

6.3. U.S. Federal Communications Commission (FCC)

CFR Title 47 Parts 15 and 18, see FCC website www.fcc.gov or contact the FCC <http://www.fcc.gov/labhelp> and submit an inquiry.

7. PRODUCT CERTIFICATION

7.1. Product Variations

Product variations are allowed so long as variations will not negatively impact a lamp's compliance with any performance criteria in this specification.

Variants shall be identical to the tested representative model with the exception of allowed variations listed in [Table 2](#). In addition, variants are permitted to reference the test reports of the tested representative model to satisfy certification requirements with the exception of the required tests outlined in [Table 2](#). The model which the partner expects to have the greatest difficulty meeting the performance requirements outlined in this specification shall be tested ("tested representative model").

The following shall be satisfied for product variations listed below:

- 7.1.1. The tested representative model and the variant(s) shall have the same rated input voltage(s).
- 7.1.2. Across a sample of up to five units of a variant, the average of *in situ* temperatures of critical components shall be no greater than 2.5°C above the same average of *in situ* temperatures in a sample of up to five units of the tested representative model. Critical components include (as applicable) the highest temperature LED package/array/module measured at TMP_{LED} , LED driver measured at TMP_C , ballast case temperature at T_C , capacitors and fuses.
- 7.1.3. For solid-state lamps, variation is not allowed where the *in situ* temperatures measured at each unit's highest temperature or the average of up to 5 unit samples TMP_{LED} is greater than the maximum case temperature tested in the corresponding IES LM-80 report.
- 7.1.4. OSHA NRTL safety listing or certification report shall be available that includes descriptions of both the tested representative model and variant(s) demonstrating their identical construction except for the allowable variations detailed in [Table 2](#), as applicable.
- 7.1.5. Test report(s) shall be available from EPA-recognized laboratory(ies) for the tested representative model and the variant(s) demonstrating that variant performance for the following parameters varies by no more than the percent indicated while meeting this specification's requirements:
 - i. Input current and input wattage: $\pm 10\%$
 - ii. Power factor: $\pm 5\%$
 - iii. Maximum overall length, except as affected only by variations in lamp base or envelope shape: $\pm 5\%$
 - iv. Maximum overall diameter: $\pm 5\%$

Table 2: Allowable Variations

Lamp Attribute	Allowable Variation	Additional Test Data Required For Each Variant ³
Heat Sink Paint Color (solid-state only)	Lamp body color/pigment. (Not the type of paint or plastic).	None
Beam Angle (solid-state only)	The dimensions of lamp secondary optics (e.g., lens thickness, refractor patterns). Variation in secondary optical material not allowed.	<ul style="list-style-type: none"> • Luminous intensity distribution data • Center Beam Intensity • Color Angular Uniformity
Lamp Base (ANSI base adapter)	Lamp base type (e.g., ANSI E26, GU24, etc.)	None
Envelope Shape (decorative shapes only)	Lamp envelope shape, so long as the envelope material and thickness are unchanged. The surface area and volume of the tested representative model's envelope shall be less than or equal to that of the variant.	None
Envelope Finish (decorative shapes only)	Lamp envelope finish, so long as the envelope material and thickness are unchanged. The surface area and volume of the tested representative model's envelope shall be less than or equal to that of the variant.	<ul style="list-style-type: none"> • Luminous Efficacy • Light Output • Correlated Color Temperature • Color Rendering
Correlated Color Temperature	<p>This allows sharing of specific test data, as applicable, for CFL and SSL lamps where the only variation is in phosphor:</p> <ul style="list-style-type: none"> • Lumen Maintenance • Rated Life • Color Maintenance • Electrical Safety • Electrical - Rapid Cycle Stress, Power Factor, Transient Protection, Frequency and Start Time • Dimming Performance– Minimum and Maximum Light Output, Audible Noise, and Flicker • Lamp Shape Dimensions • Lamp Toxics Reduction <p>Only the tested representative model is required to complete lumen maintenance and full rated life testing as applicable.</p>	<ul style="list-style-type: none"> • Luminous Efficacy • Light Output • Elevated Temperature Light Output Ratio (as applicable) • Center Beam Intensity (as applicable) • Luminous Intensity Distribution (as applicable) • Correlated Color Temperature • Color Rendering • Color Angular Uniformity (SSL only and as applicable) • Run-Up Time (CFLs only)
Lamp Neck	Applicable to PAR30 Long Neck (PAR30L) lamps where the representative model has the shortest MOL, and the only component changed is the neck of the lamp. Changes to heat sink or driver are not allowed.	None

7.2. Solid-State Lumen Maintenance Performance Data

Content and application of IES LM-80 reports for LED lamps shall comply with [ENERGY STAR Program Guidance](#) Regarding LED Package, LED Array and LED Module Lumen Maintenance Performance Data Supporting Certification of Lighting Products.

7.3. Temperature Measurements

All temperature measurements including *in situ* measurements (i.e., TMP_{LED}, ballast case, driver case) shall be made in accordance with temperature test methods and apparatus outlined in ANSI/UL 1993. For purposes of thermocouple access, minimally sized holes may be drilled into lamps under test and tightly sealed with flexible sealant. All access holes shall be photographed for repeatability.

7.4. Photographs

Photographs shall be taken of lamp optics, lamp profile and lamp labeling, and shall be maintained in records.

7.5. Significant Digits and Rounding

7.5.1. Measurements shall be recorded at the resolution of the test instrumentation for each unit in the sample set.

³ All variations listed in Table 2 shall satisfy the requirements in 7.1.1-7.1.5 in addition to the additional test data required in Table 2.

- 7.5.2. All calculations shall be carried out on a per unit basis with directly measured (unrounded) values.
- 7.5.3. Compliance with the specification limits shall be evaluated against the reported value for each model.
- 7.5.4. Rounding is defined as follows:
- (i) A fractional number at or above the midpoint between two consecutive decimal places or whole numbers shall be rounded up to the higher of the two decimal places or whole numbers; or
 - (ii) A fractional number below the midpoint between two consecutive decimal places or whole numbers shall be rounded down to the lower of the two decimal places or whole number.

8. METHODS OF MEASUREMENT AND REFERENCE DOCUMENTS

Organization	Identifier	Description
ANSI/IEEE	C62.41.2-2002	IEEE Recommended Practice on Characterization of Surges in Low Voltage (1000V and Less) AC Power Circuits
ANSI	C78.20-2003	Electric Lamps – A, G, PS and Similar Shapes with E26 Medium Screw Bases
ANSI	C78.21-2011	Electric Lamps – PAR and R Shapes
ANSI	C78.50-2014	Electric Lamps – Assigned LED Lamp Codes
ANSI	C78.79-2014	Electric Lamps – Nomenclature for Envelope Shapes Intended for Use with Electric Lamps
ANSI	C78.23:1995 (R2003)	Incandescent Lamps – Miscellaneous Types
ANSI/ANSLG	C78.357-2010	For Incandescent Lamps: Tungsten Halogen Lamps (non-vehicle)
ANSI	C78.376-2014	Specifications for the Chromaticity of Fluorescent Lamps
ANSI/ANSLG	C78.377-2015	Specifications for the Chromaticity of Solid-state Lighting Products
ANSI	C79.1-2002	Nomenclature for Glass Bulbs Intended for Use with Electric Lamps
ANSI/ANSLG	C81.61-2009	Specifications for Bases (Caps) for Electric Lamps
ANSI	C82.77-10-2014	Harmonic Emission Limits – Related Power Quality Requirements for Lighting Equipment
ANSI/IES	RP-16-10	Nomenclature and Definitions for Illuminating Engineering
ANSI/UL	1993-2012	Standard for Safety of Self-Ballasted Lamps and Lamp Adapters
ANSI/UL	8750-2009	Standard for Light Emitting Diode (LED) Equipment for Use in Lighting Products
ASA	S12.55-2012 / ISO3745:2012	Determination of Sound Power Levels of Noise Sources Using Sound Pressure - Precision Methods Anechoic and Hemi-Anechoic Rooms
CIE	013.3-1995	Method of Measuring and Specifying Color Rendering of Light Sources
CIE	15-2004	Colorimetry
DOE	10 CFR 429	Certification, Compliance, and Enforcement for Consumer Products and Commercial and Industrial Equipment
DOE	10 CFR 430	Energy Conservation Program for Consumer Products
DOE	TBD	Energy Conservation Test Procedures for Compact Fluorescent Lamps
DOE	TBD	Energy Conservation Test Procedure for Integrated Light-Emitting Diode Lamps
IEC	62321 ED.1.0 B:2008	Electrotechnical Products – Determination Of Levels Of Six Regulated Substances (lead, mercury, cadmium, hexavalent chromium, polybrominated biphenyls, polybrominated diphenyl ethers)
IEC	62301 Edition 2.0 2011-01	Household electrical appliances - Measurement of standby power
IEEE	1789-2015	Recommended Practices for Modulating Current in High-Brightness LEDs for Mitigating Health Risks to Viewers
IES	LM-20-13	Photometric Testing of Reflector – Type Lamps
IES	LM-54-12	Guide to Lamp Seasoning
IES	LM-65-14	Life Testing of Compact Fluorescent Lamps
IES	LM-66-14	Electrical and Photometric Measurements of Single-Ended Compact Fluorescent Lamps
IES	LM-79-08	Electrical and Photometric Measurements of Solid-State Lighting Products
IES	LM-80-08	Measuring Lumen Maintenance of LED Light Sources
IES	LM-82-12	Method for the Characterization of LED Light Engines and Integrated LED Lamps for Electrical and Photometric Properties as a Function of Temperature
IES	LM-84-14	Measuring Luminous Flux and Color Maintenance of LED Lamps, Light Engines, and Luminaires
IES	TM-21-11	Projecting Long Term Lumen Maintenance of LED Light Sources
IES	TM-28-14	Projecting Long-Term Luminous Flux Maintenance of LED Lamps and Luminaires
IES	TM-30-15	Evaluating Light Source Color Rendition
ISO	7574-4:1985	Statistical Methods for Determining and Verifying Stated Noise Emission Values of Machinery and Equipment
NEMA	SSL 7A-2013	Phase Cut Dimming for Solid-State Lighting – Basic Compatibility

9. PHOTOMETRIC PERFORMANCE

9.1. Luminous Efficacy: All Lamps

Lamp Type	ENERGY STAR Requirements		Methods of Measurement and/or Reference Documents	Supplemental Testing Guidance
	<p>Reported values for each lamp model shall meet the applicable requirement in the table below. Additionally eight or more units individually shall meet the requirement.</p>		<p>Measurement (fluorescent): 10 CFR Part 430 Appendix W to Subpart B or U.S. Department of Energy Conservation Test Procedures for Compact Fluorescent Lamps (once final)</p> <p>Measurement (solid-state): IES LM-79-08 or U.S. Department of Energy Conservation Test Procedure for Integrated Light-Emitting Diode Lamps (once final)</p> <p>Reference Documents for all lamps not covered by DOE: IES LM-54-12</p>	<p>Sample Size: 10 units per model: 5 units tested base-up and 5 units tested base-down unless the manufacturer restricts specific use or position. If position is restricted, all units shall be tested in restricted position.</p> <p>For CFLs lamp efficacy testing shall be conducted according to 10 CFR Part 430 Appendix W to Subpart B and sampling per 10 CFR 429.35. The reported value shall be in accordance with 10 CFR 429.</p> <p>For LED lamps all calculations of efficacy values shall be carried out on a per unit basis with directly measured (unrounded) values. No tolerances should be applied and the reported value for the sample shall be the average of the calculated efficacies (initial luminous flux divided by measured wattage) for all units in the sample. The reported value shall be the average of the unit values rounded to the nearest tenth.</p>
	<p>Minimum Lamp Efficacy (initial lm/W)</p>			
	CRI ≥ 90	CRI < 90		
Omnidirectional	70	80		
Directional	61	70		
Decorative	65			

9.2. Light Output

Wattage equivalency claims on the lamp, its base or packaging, product literature or point-of-purchase materials, either printed or electronic may not exceed values certified according to the tables below.

Lamp Type	ENERGY STAR Requirements	Methods of Measurement and/or Reference Documents	Supplemental Testing Guidance																										
Omnidirectional	<p>Reported initial light output (in lumens) value for each lamp model shall fall within the range of the referenced incandescent lamp per the table below. Additionally 8 or more units individually shall meet the requirement.⁴</p> <table border="1" data-bbox="399 485 915 869"> <thead> <tr> <th>Rated Wattage of the Referenced Incandescent Lamp (watts)</th> <th>Light Output (Lumens)</th> </tr> </thead> <tbody> <tr><td>25</td><td>250–449</td></tr> <tr><td>40</td><td>450–799</td></tr> <tr><td>60</td><td>800–1,099</td></tr> <tr><td>75</td><td>1,100–1,599</td></tr> <tr><td>100</td><td>1,600–1,999</td></tr> <tr><td>125</td><td>2,000–2,549</td></tr> <tr><td>150</td><td>2,550–3,000</td></tr> <tr><td>200</td><td>3,001–3,999</td></tr> <tr><td>300</td><td>4,000–6,000</td></tr> <tr><td>30-60-100</td><td rowspan="3">1,200–1,999</td></tr> <tr><td>30-70-100</td></tr> <tr><td>40-60-100</td></tr> <tr><td>50-100-150</td><td>2,150–3,000</td></tr> </tbody> </table> <p>3-way lamps shall be evaluated for equivalency claims based on tested results at the highest input (i.e., highest light output) setting.</p>	Rated Wattage of the Referenced Incandescent Lamp (watts)	Light Output (Lumens)	25	250–449	40	450–799	60	800–1,099	75	1,100–1,599	100	1,600–1,999	125	2,000–2,549	150	2,550–3,000	200	3,001–3,999	300	4,000–6,000	30-60-100	1,200–1,999	30-70-100	40-60-100	50-100-150	2,150–3,000	<p>Measurement (fluorescent): 10 CFR Part 430 Appendix W to Subpart B or U.S. Department of Energy Conservation Test Procedures for Compact Fluorescent Lamps (once final)</p> <p>Measurement (solid-state): IES LM-79-08 or U.S. Department of Energy Conservation Test Procedure for Integrated Light-Emitting Diode Lamps (once final)</p>	<p>Sample Size: 10 units per model: 5 units tested base-up and 5 units tested base-down unless the manufacturer restricts specific use or position. If position is restricted, all units shall be tested in restricted position.</p> <p>For CFL lamps the light output testing shall be conducted according to 10 CFR Part 430 Appendix W to Subpart B and sampling per 10 CFR 429.35. The reported value shall be in accordance with 10 CFR 429.</p> <p>For LED lamps the reported value shall be the average of the unit measured values rounded to three significant figures. No tolerances shall be applied.</p>
Rated Wattage of the Referenced Incandescent Lamp (watts)	Light Output (Lumens)																												
25	250–449																												
40	450–799																												
60	800–1,099																												
75	1,100–1,599																												
100	1,600–1,999																												
125	2,000–2,549																												
150	2,550–3,000																												
200	3,001–3,999																												
300	4,000–6,000																												
30-60-100	1,200–1,999																												
30-70-100																													
40-60-100																													
50-100-150	2,150–3,000																												
Directional (R, BR and ER)	<p>Reported lamp initial light output (in lumens) shall be greater than or equal to ten times the incandescent lamp's rated wattage for the following referenced incandescent lamps:</p> <ul style="list-style-type: none"> • 65 watt BR30, BR40 and ER40 lamps • BR30, ER30, BR40 and ER40 lamps ≤ 50 watts • R20 lamps ≤ 45 watts • Lamps ≤ 40 watts • Lamps smaller than 2.25" diameter <p>For example, a lamp replacing a 25W incandescent shall produce ≥ 250 lumens.</p> <p>For all other directional lamps not included above, reported lamp light output (in lumens) shall be greater than or equal to the product of the claimed wattage equivalency and the light output multiplier in the table below. Additionally 8 or more units individually shall meet the requirement.</p> <table border="1" data-bbox="399 1423 915 1654"> <thead> <tr> <th>Rated Wattage of the Referenced Incandescent Lamp (watts)</th> <th>Light Output Multiplier</th> </tr> </thead> <tbody> <tr><td>40 – 50 W</td><td>10.5</td></tr> <tr><td>51 – 66 W</td><td>11.0</td></tr> <tr><td>67 – 85 W</td><td>12.5</td></tr> <tr><td>86 – 115 W</td><td>14.0</td></tr> <tr><td>116 – 155 W</td><td>14.5</td></tr> <tr><td>156 – 205 W</td><td>15.0</td></tr> </tbody> </table>	Rated Wattage of the Referenced Incandescent Lamp (watts)	Light Output Multiplier	40 – 50 W	10.5	51 – 66 W	11.0	67 – 85 W	12.5	86 – 115 W	14.0	116 – 155 W	14.5	156 – 205 W	15.0	<p>Reference Documents: IES LM-54-12</p> <p>Reference Document for all lamps covered by FTC: 16 CFR § 305.2.</p>													
Rated Wattage of the Referenced Incandescent Lamp (watts)	Light Output Multiplier																												
40 – 50 W	10.5																												
51 – 66 W	11.0																												
67 – 85 W	12.5																												
86 – 115 W	14.0																												
116 – 155 W	14.5																												
156 – 205 W	15.0																												
Directional (PAR, MR and MRX)	<p>Lamp initial light output (in lumens) shall be reported as the average of ten units. For equivalency claims see section 9.4.</p>																												

⁴Consistent with FTC and DOE regulations, reported values may be more conservative.

Decorative	Reported lamp initial light output (in lumens) shall fall within the range of the referenced incandescent lamp per the table below. Additionally 8 or more units individually shall meet the requirement.			
	Rated Wattage of the Referenced Incandescent Lamp (watts)	Light Output (Lumens)		
		Decorative	Globe (G) Shape	
	10	70–89	--	
	15	90–149	--	
	25	150–299	250–349	
	40	300–499	350–499	
	60	500–699	500–574	
	75	--	575–649	
	100	--	650–1,099	
125	--	--		
150	--	1,100–1,300		

9.3. Elevated Temperature Light Output Ratio: All Directional Lamps
 (Exemption: Omnidirectional, decorative, and lamps labeled “not for use in recessed fixtures” or equivalent statement)

Lamp Type	ENERGY STAR Requirements	Methods of Measurement and/or Reference Documents	Supplemental Testing Guidance
All Directional	Lamp shall maintain $\geq 90\%$ of initial light output (total luminous flux) measured at ambient temperature ($25^{\circ}\text{C} \pm 5^{\circ}\text{C}$) when tested in the same elevated temperature condition required by the Lumen Maintenance requirement. Calculation of the elevated temperature light output ratio shall be carried out with directly measured (unrounded) values.	Measurement: ENERGY STAR Elevated Temperature Light Output Ratio Test or IES LM-82-12	Sample Size: One unit tested base-up. The reported value shall be the calculated ratio for the unit rounded to the nearest tenth. To utilize LM-82-12, the partner must designate a temperature measurement point (T_b) for attaching the thermocouple.

9.4. Center Beam Intensity: PAR, MR and MRX Lamps

Wattage equivalency claims on the lamp, its base or packaging, product literature or point-of-purchase materials, either printed or electronic may not exceed values certified. This specification does not support equivalency claims to reference incandescent or halogen products that have not been commercially available.

Lamp Type	ENERGY STAR Requirements	Methods of Measurement and/or Reference Documents	Supplemental Testing Guidance
ANSI Standard PAR, MR and MRX Lamps	Lamp center beam intensity measured value shall be greater than or equal to the center beam intensity value calculated by the ENERGY STAR® Lamp Center Beam Intensity Benchmark Tool for the referenced incandescent lamp. (www.energystar.gov/LampsCBCP) For equivalency claims not supported by this tool, lamp must meet or exceed the measured center beam candlepower (CBCP) of the referenced incandescent or halogen product with the same nominal beam spread.	Measurement (fluorescent): IES LM-66-14 Measurement (solid-state): IES LM-79-08 Measurement (incandescent): IES LM-20-13 Reference Documents: IES LM-54-12	Sample Size: One new unit. The sample may be the same unit for testing color angular uniformity as applicable. The reported value shall be the measured candela value rounded to the nearest whole number.

9.5. Luminous Intensity Distribution: ANSI Standard Omnidirectional and Decorative

Lamp Type	ENERGY STAR Requirements	Methods of Measurement and/or Reference Documents	Supplemental Testing Guidance
ANSI Standard Omnidirectional Lamps Refer to Section 1.1 for eligible ANSI standard lamp shapes	Lamp luminous intensity distribution shall emulate that of the referenced incandescent lamp as follows: 80% of the luminous intensity measured values (candelas) shall vary by no more than 35% from the average of all measured values in the 0° to 130° zone. All measured values (candelas) in the 0° to 130° zone shall vary by no more than 60% from the average of all measured values in that zone. No less than 5% of total flux (zonal lumens) shall be emitted in the 130° to 180° zone. See Appendix A-1 for illustration.	Measurement (solid-state): IES LM-79-08 Reference Document: ENERGY STAR Luminous Intensity Distribution Tool	Sample Size: One unit. Lamp luminous intensity shall be measured about the lamp (polar) axis, in maximum increments of 22.5° from 0° to at least 180° about the polar axis. Within each vertical plane luminous intensity measurements shall be taken from 0° to 180° at 5° vertical angle increments (maximum).
ANSI Standard Decorative Lamps Refer to Section 1.1 for eligible ANSI standard lamp shapes	Lamp luminous intensity distribution shall emulate that of the referenced incandescent lamp as follows: No less than 5% of total flux (lumens) shall be emitted in the 110° to 180° zone. See Appendix A-2 for illustration.		Sample Size: One unit.

9.6. Correlated Color Temperature (CCT): All Lamps

Lamp Type	ENERGY STAR Requirements	Methods of Measurement and/or Reference Documents	Supplemental Testing Guidance
Compact Fluorescent	Reported lamp model light color temperature shall correlate to one of the following nominal CCTs, additionally 9 out of 10 units shall fall within a 7-step MacAdam ellipse or ANSI quadrangle for the designated CCT, per the referenced ANSI document: <ul style="list-style-type: none"> • 2200K* • 2500K* • 2700K • 3000K • 3500K • 4000/4100K • 5000K • 6500K 	Measurement: IES LM-66-14 or U.S. Department of Energy Conservation Test Procedures for Compact Fluorescent Lamps (once final) Calculation: CIE 15-2004 Reference Documents: ANSI C78.376-2014 Sections 2 and 4, and Table 2 IES LM-54-12	Sample Size: 10 units per model: 5 units tested base-up and 5 units tested base-down unless the manufacturer restricts specific use or position. If position is restricted, all units shall be tested in restricted position. Measurements shall be taken at the end of 100 hours of seasoning according to IES LM-54-12. Reported CCT shall be the average of the unit measured values rounded to the nearest 100K.
Solid-State		Measurement: IES LM-79-08 or U.S. Department of Energy Conservation Test Procedure for Integrated Light-Emitting Diode Lamps (once final) Calculation: CIE 15.2004 Reference Document: ANSI C78.377-2015	Sample Size: 10 units per model: 5 units tested base-up and 5 units tested base-down unless the manufacturer restricts specific use or position. If position is restricted, all units shall be tested in restricted position. Reported CCT shall be the average of the unit measured values rounded to the nearest 100K.

*These nominal CCTs are limited to filament-style lamps and are not eligible for early interim certification.

9.7. Color Rendering: All Lamps

Lamp Type	ENERGY STAR Requirements	Methods of Measurement and/or Reference Documents	Supplemental Testing Guidance
Compact Fluorescent	Lamp shall have a color rendering index (R_a) ≥ 80 . The average of units tested shall meet the requirements and no more than 3 units shall have $R_a < 77$. No unit shall have $R_a < 75$. Lamp R_9 value shall be Spectral power distribution shall be reported for wavelengths of 380 nm and 780 nm (at a minimum), with an interval not greater than 5 nm.	Calculation: CIE 13.3-1995 or U.S. Department of Energy Conservation Test Procedure for Compact Fluorescent Lamps (once final) Measurement: IES LM-66-14 or U.S. Department of Energy Conservation Test Procedure for Compact Fluorescent Lamps (once final) IES TM-30-15	Sample Size: 10 units per model: 5 units tested base-up and 5 units tested base-down unless the manufacturer restricts specific use or position. If position is restricted, all units shall be tested in restricted position. Reported values shall be the average of the unit measured values rounded to the nearest whole number.
Solid-State	Lamp shall have a color rendering index (R_a) ≥ 80 . The average of units tested shall meet the requirements and no more than 3 units shall have $R_a < 77$. No unit shall have $R_a < 75$. Lamp shall have an $R_9 > 0$. Spectral power distribution shall be reported for wavelengths of 380 nm and 780 nm (at a minimum), with an interval not greater than 5 nm.	Calculation: CIE 13.3-1995 or U.S. Department of Energy Conservation Test Procedure for Integrated Light-Emitting Diode Lamps (once final) Measurement: IES LM-79-08 or U.S. Department of Energy Conservation Test Procedure for Integrated Light-Emitting Diode Lamps (once final) IES TM-30-15	

9.8. Color Maintenance: All Solid-State Lamps

(Exemption: Compact Fluorescent Lamps)

Lamp Type	ENERGY STAR Requirements	Methods of Measurement and/or Reference Documents	Supplemental Testing Guidance
Solid-State	Lamp change in chromaticity coordinates from 0-hour measurement, at any measurement point required by the specification or reference test method during operation, shall be within a total linear distance of 0.007 on the CIE 1976 $u'v'$ diagram. All units shall meet this requirement.	Measurement: IES LM-79-08 IES LM-80-08 (for early interim certification) or IES LM-84-14 in conjunction with U.S. Department of Energy Conservation Test Procedure for Integrated Light-Emitting Diode Lamps (once final) Reference Document: ANSI C78.377-2015	Sample Size: 10 units per model: 5 units tested base-up and 5 units tested base-down unless the manufacturer restricts specific use or position. If position is restricted, all units shall be tested in restricted position. Reported color maintenance shall be the calculated value for each unit rounded to the nearest significant digit.

9.9. Color Angular Uniformity: Solid-State Directional Lamps

(Exemption: All Other Lamps)

Lamp Type	ENERGY STAR Requirements	Methods of Measurement and/or Reference Documents	Supplemental Testing Guidance
Solid-State Directional	Variation of chromaticity across the beam angle of the lamp shall be within a total linear distance of 0.006 from the weighted average point on the CIE 1976 ($u'v'$) diagram.	Measurement: IES LM-79-08 Reference Document: ANSI C78.377-2015	Sample Size: One unit. The sample may be the same unit for testing Center Beam Intensity, as applicable. Lamp shall be scanned on two planes separated by 90 degrees. Maximum vertical scanning resolution shall be 2° for beam angles less than 15° and 5° for beam angles 15° or greater. Complete luminous intensity distribution data shall be reported.

10. LUMEN MAINTENANCE AND RATED LIFE

Required durations of lumen maintenance and rapid cycle stress testing corresponding to lamp's rated life claim shall be completed. Rated life claims on the lamp, its base or packaging, product literature or point-of-purchase materials, either printed or electronic may not exceed values certified according to this specification. The highest wattage, be it the measured wattage of a single unit sample or the rated wattage for the model, should be used to determine the testing temperature.

10.1. Lumen Maintenance: All Lamps

Lamp Type	ENERGY STAR Requirements	Methods of Measurement and/or Reference Documents	Supplemental Testing Guidance																		
Compact Fluorescent	<p>Lamp shall maintain $\geq 90\%$ of initial lumen output at 1,000-hours. The reported value shall be the average lumen maintenance of 10 units. All units shall be surviving at 1,000-hours.</p> <p>Lamp shall maintain $\geq 80\%$ of initial lumen output at 40% of rated life. The reported value shall be the average lumen maintenance of 10 units, and shall meet the requirement for the designated life claim, and no more than 3 units may have lumen maintenance $< 75\%$ at 40% of rated life.</p> <p>Initial Certification: A product may be certified based on partial life testing, and shall meet all other requirements of the specification as certified by an EPA-recognized Certification Body. Initial certification occurs at 40% of rated life for CFLs and 3,000 hours for LED lamps. A product photo is required to identify the current version of the certified product.</p> <p>Packaging Review: Electronic or hard copy labeling and packaging samples are required for the specific model. Packaging must meet all of the requirements identified under the Lifetime and Packaging Requirements. The specific certified model must be distributed within this approved product packaging.</p> <p>Due Date: A due date for the final average rated life time test report must be established based on the date the lifetime test began and the rated lifetime of the model. Products that meet the above requirements may be considered certified for ENERGY STAR and may be labeled.</p> <p>Full Qualification: The final rated life time test results must be certified within 60 days of completion of the test and must demonstrate that the product meets the rated lifetime claim established during initial certification.</p> <p>Upgrading the Lifetime of a Certified Product: The lifetime of a product certified using the procedures above may be increased</p>	<p>Measurement (fluorescent): ENERGY STAR Elevated Temperature Life Test</p> <p>IES LM-65-14 IES LM-66-14</p> <p>10 CFR Part 429 and Part 430 Appendix W to Subpart B as applicable</p> <p>Reference Documents for all lamps not covered by DOE: IES LM-54-12</p>	<p>Sample Size: 10 units per model: 5 units tested base-up and 5 units tested base-down unless the manufacturer restricts specific use or position. If position is restricted, all units shall be tested in restricted position. If Option A is selected then all 10 lamps may be tested base-up. The sample size for lamps covered by DOE's regulatory program that require elevated temperature life testing as prescribed below shall include sampling and testing in accordance with 10 CFR 430 Appendix W to Subpart B and only 5 units tested at the elevated temperature as prescribe below.</p> <p>Prescribed test time is the total ON time and shall not include the OFF time during lamp cycling.</p> <p>The following shall be tested according to the test standard and operating temperatures outlined below:</p> <table border="1"> <thead> <tr> <th>Lamp Type/Wattage</th> <th>Methods of Measurement and/or Reference Documents</th> <th>Operating Temperature</th> </tr> </thead> <tbody> <tr> <td>Lamps labeled "not for use in totally enclosed luminaires" and/or "not for use in recessed luminaires" or equivalent statement on lamp and lamp packaging</td> <td>IES LM-65-14; IES LM-66-14 for photometric measurements; 10 CFR Appendix W to Subpart B</td> <td>Ambient temperature conditions (25°C \pm1°C)</td> </tr> <tr> <td>Directional lamps ≤ 20 watts</td> <td>ENERGY STAR Elevated Temperature Life Test</td> <td>Option A or B or C at 45°C \pm5°C</td> </tr> <tr> <td>Directional lamps > 20 watts</td> <td>ENERGY STAR Elevated Temperature Life Test</td> <td>Option A or B or C at 55°C \pm5°C</td> </tr> <tr> <td>All other lamps not covered by DOE</td> <td>ENERGY STAR Elevated Temperature Life Test</td> <td>Option A or B or C at 45°C \pm5°C</td> </tr> <tr> <td>Lamps covered by DOE</td> <td>IES LM-65-14; IES LM-66-14 for photometric measurements; 10 CFR Appendix W to Subpart B</td> <td>Ambient temperature conditions (25°C \pm1°C)</td> </tr> </tbody> </table> <p>For CFLs not covered by DOE's regulatory program, initial lumen output measurements shall be taken at the end of 100 hours of seasoning according to IES LM-54-12. The reported value shall</p>	Lamp Type/Wattage	Methods of Measurement and/or Reference Documents	Operating Temperature	Lamps labeled "not for use in totally enclosed luminaires" and/or "not for use in recessed luminaires" or equivalent statement on lamp and lamp packaging	IES LM-65-14; IES LM-66-14 for photometric measurements; 10 CFR Appendix W to Subpart B	Ambient temperature conditions (25°C \pm 1°C)	Directional lamps ≤ 20 watts	ENERGY STAR Elevated Temperature Life Test	Option A or B or C at 45°C \pm 5°C	Directional lamps > 20 watts	ENERGY STAR Elevated Temperature Life Test	Option A or B or C at 55°C \pm 5°C	All other lamps not covered by DOE	ENERGY STAR Elevated Temperature Life Test	Option A or B or C at 45°C \pm 5°C	Lamps covered by DOE	IES LM-65-14; IES LM-66-14 for photometric measurements; 10 CFR Appendix W to Subpart B	Ambient temperature conditions (25°C \pm 1°C)
Lamp Type/Wattage	Methods of Measurement and/or Reference Documents	Operating Temperature																			
Lamps labeled "not for use in totally enclosed luminaires" and/or "not for use in recessed luminaires" or equivalent statement on lamp and lamp packaging	IES LM-65-14; IES LM-66-14 for photometric measurements; 10 CFR Appendix W to Subpart B	Ambient temperature conditions (25°C \pm 1°C)																			
Directional lamps ≤ 20 watts	ENERGY STAR Elevated Temperature Life Test	Option A or B or C at 45°C \pm 5°C																			
Directional lamps > 20 watts	ENERGY STAR Elevated Temperature Life Test	Option A or B or C at 55°C \pm 5°C																			
All other lamps not covered by DOE	ENERGY STAR Elevated Temperature Life Test	Option A or B or C at 45°C \pm 5°C																			
Lamps covered by DOE	IES LM-65-14; IES LM-66-14 for photometric measurements; 10 CFR Appendix W to Subpart B	Ambient temperature conditions (25°C \pm 1°C)																			

	<p>only by demonstrating full compliance with the ENERGY STAR criteria at the new lifetime. Packaging proofs must be reviewed as in the initial certification process.</p> <table border="1" data-bbox="349 279 730 449"> <thead> <tr> <th>Rated Lifetime (hours)</th> <th>Early Interim (40% Rated Life) (hours)</th> <th>Full Certification (hours)</th> </tr> </thead> <tbody> <tr> <td>10,000</td> <td>4,000</td> <td>10,000</td> </tr> <tr> <td>12,000</td> <td>4,800</td> <td>12,000</td> </tr> <tr> <td>15,000</td> <td>6,000</td> <td>15,000</td> </tr> <tr> <td>20,000</td> <td>8,000</td> <td>20,000</td> </tr> </tbody> </table>	Rated Lifetime (hours)	Early Interim (40% Rated Life) (hours)	Full Certification (hours)	10,000	4,000	10,000	12,000	4,800	12,000	15,000	6,000	15,000	20,000	8,000	20,000		<p>be the average of the unit values rounded to the nearest tenth of a percent.</p> <p>For CFLs covered by DOE's regulatory program (i.e., medium base CFLs without reflectors or 3-way capabilities), the value should be calculated according to the 10 CFR 429.35.</p> <p>Subsequent to initial certification, it is suggested that initial Rapid Cycle Stress Test be completed in anticipation of final product lifetime. The following tests must be completed: Rapid Cycle Stress Test, Lumen Maintenance, Interim Life and Lifetime Test.</p>																														
Rated Lifetime (hours)	Early Interim (40% Rated Life) (hours)	Full Certification (hours)																																														
10,000	4,000	10,000																																														
12,000	4,800	12,000																																														
15,000	6,000	15,000																																														
20,000	8,000	20,000																																														
<p>Solid-State</p>	<p>Lamp shall maintain minimum percentage of 0-hour light output after completion of the 6000-hr test duration per the table(s) below. The reported value shall be the average lumen maintenance of 10 units and shall meet the minimum requirement for the designated lifetime claim in Section 10.2. Lamp may earn optional early interim certification after 3,000 hours, with a rated life claim \leq 25,000 hours, per the provisions below.</p> <table border="1" data-bbox="349 783 740 1108"> <thead> <tr> <th>Maximum Life Claim (hours to L_{70})</th> <th>Minimum Lumen Maintenance After Test Duration</th> <th>Status After Completion of Test Duration</th> </tr> </thead> <tbody> <tr> <td>15,000</td> <td>86.7%</td> <td rowspan="3">Final certification testing completed.</td> </tr> <tr> <td>20,000</td> <td>89.9%</td> </tr> <tr> <td>25,000</td> <td>91.8%</td> </tr> <tr> <td>30,000</td> <td>93.1%</td> <td rowspan="4">Interim certification; continue testing per below.</td> </tr> <tr> <td>35,000</td> <td>94.1%</td> </tr> <tr> <td>40,000</td> <td>94.8%</td> </tr> <tr> <td>45,000</td> <td>95.4%</td> </tr> <tr> <td>50,000</td> <td>95.8%</td> <td></td> </tr> </tbody> </table> <p>To Qualify For Early Interim Certification After 3,000 Hours: Lamp average lumen maintenance of the 10 units shall meet the minimum percentages of 0-hour light output corresponding to the lamp's life claim per the table below, and shall meet all other requirements in this specification. A lumen maintenance projection calculation using the applicable LM-80-08 test report for the employed LED package/module/array model ("device"), the <i>in situ</i> temperature of highest temperature TMP_{LED}, and the forward drive current applied to each device shall support a rated lumen maintenance life greater than or equal to the lamp rated life value to be claimed on product packaging as determined by IES TM-21-11.</p> <table border="1" data-bbox="349 1644 727 1797"> <thead> <tr> <th>Maximum Life Claim (hours to L_{70})</th> <th>Minimum Lumen Maintenance After 3,000 Hours</th> </tr> </thead> <tbody> <tr> <td>15,000</td> <td>93.1%</td> </tr> <tr> <td>20,000</td> <td>94.8%</td> </tr> <tr> <td>25,000</td> <td>95.8%</td> </tr> </tbody> </table> <p>For Extended Lifetime Claims: For lamp life claims $>$25,000 hours, lamp shall maintain \geq 91.5% of 0-hour light output after completion of the test</p>	Maximum Life Claim (hours to L_{70})	Minimum Lumen Maintenance After Test Duration	Status After Completion of Test Duration	15,000	86.7%	Final certification testing completed.	20,000	89.9%	25,000	91.8%	30,000	93.1%	Interim certification; continue testing per below.	35,000	94.1%	40,000	94.8%	45,000	95.4%	50,000	95.8%		Maximum Life Claim (hours to L_{70})	Minimum Lumen Maintenance After 3,000 Hours	15,000	93.1%	20,000	94.8%	25,000	95.8%	<p>Method of Measurement (lamps): ENERGY STAR Elevated Temperature Life Test</p> <p>ENERGY STAR Ambient Temperature Life Test</p> <p>LED Lumen Maintenance Test Method: IES LM-80-08</p> <p>Lumen Maintenance Projection Method: IES TM-21-11</p> <p>Reference Document: ENERGY STAR TM-21 Calculator</p> <p>Or: U.S. Department of Energy Conservation Test Procedure for Integrated Light-Emitting Diode Lamps (once final)</p>	<p>Sample Size: 10 units per model: 5 units tested base-up and 5 units tested base-down unless the manufacturer restricts specific use or position. If position is restricted, all units shall be tested in restricted position. If Option A is selected then all 10 lamps may be tested base-up.</p> <p>The following shall be tested according to the test standard and operating temperatures outlined below:</p> <table border="1" data-bbox="959 735 1466 1339"> <thead> <tr> <th>Lamp Type/Wattage</th> <th>Methods of Measurement and/or Reference Documents*</th> <th>Operating Temperature</th> </tr> </thead> <tbody> <tr> <td>Lamps labeled "not for use in totally enclosed luminaires" and/or "not for use in recessed luminaires" or equivalent statement on lamp and lamp packaging</td> <td>ENERGY STAR Ambient Temperature Life Test</td> <td>Between 20°C and 35°C</td> </tr> <tr> <td>Directional lamps \leq 20 watts</td> <td>ENERGY STAR Elevated Temperature Life Test</td> <td>Option A or B or C at 45°C \pm5°C</td> </tr> <tr> <td>Directional lamps $>$ 20 watts</td> <td>ENERGY STAR Elevated Temperature Life Test</td> <td>Option A or B or C at 55°C \pm5°C</td> </tr> <tr> <td>All other omnidirectional and decorative lamps</td> <td>ENERGY STAR Elevated Temperature Life Test</td> <td>Option A or B or C at 45°C \pm5°C</td> </tr> </tbody> </table> <p>*Temperature ranges for applicable lamp types shall remain if the DOE final test method allows.</p> <p>Testing for early interim and final certification shall be conducted on the same samples, which shall also satisfy the 6,000 hour testing for the rated life requirements (next section).</p> <p>A 3% tolerance may be applied to all measured luminous flux values (e.g., [luminous flux X 1.03]) except at the 0-hour measurement, if the calculated lumen maintenance value fails to meet the requirement without the tolerance. No other tolerances should be applied.</p> <p>Lamp Sample Size for Early Interim Certification Temperature Test: One lamp per model for <i>in situ</i> measurement of highest temperature TMP_{LED}.</p> <p>Device Sample Size for Early Interim Certification: Minimum sample size of 20 units for LED packages, or 10 units for LED arrays or LED modules, for each T_s and drive current combination (refer to IES TM-21-11, Section 4.2).</p>	Lamp Type/Wattage	Methods of Measurement and/or Reference Documents*	Operating Temperature	Lamps labeled "not for use in totally enclosed luminaires" and/or "not for use in recessed luminaires" or equivalent statement on lamp and lamp packaging	ENERGY STAR Ambient Temperature Life Test	Between 20°C and 35°C	Directional lamps \leq 20 watts	ENERGY STAR Elevated Temperature Life Test	Option A or B or C at 45°C \pm 5°C	Directional lamps $>$ 20 watts	ENERGY STAR Elevated Temperature Life Test	Option A or B or C at 55°C \pm 5°C	All other omnidirectional and decorative lamps	ENERGY STAR Elevated Temperature Life Test	Option A or B or C at 45°C \pm 5°C
Maximum Life Claim (hours to L_{70})	Minimum Lumen Maintenance After Test Duration	Status After Completion of Test Duration																																														
15,000	86.7%	Final certification testing completed.																																														
20,000	89.9%																																															
25,000	91.8%																																															
30,000	93.1%	Interim certification; continue testing per below.																																														
35,000	94.1%																																															
40,000	94.8%																																															
45,000	95.4%																																															
50,000	95.8%																																															
Maximum Life Claim (hours to L_{70})	Minimum Lumen Maintenance After 3,000 Hours																																															
15,000	93.1%																																															
20,000	94.8%																																															
25,000	95.8%																																															
Lamp Type/Wattage	Methods of Measurement and/or Reference Documents*	Operating Temperature																																														
Lamps labeled "not for use in totally enclosed luminaires" and/or "not for use in recessed luminaires" or equivalent statement on lamp and lamp packaging	ENERGY STAR Ambient Temperature Life Test	Between 20°C and 35°C																																														
Directional lamps \leq 20 watts	ENERGY STAR Elevated Temperature Life Test	Option A or B or C at 45°C \pm 5°C																																														
Directional lamps $>$ 20 watts	ENERGY STAR Elevated Temperature Life Test	Option A or B or C at 55°C \pm 5°C																																														
All other omnidirectional and decorative lamps	ENERGY STAR Elevated Temperature Life Test	Option A or B or C at 45°C \pm 5°C																																														

	<p>duration corresponding to lamp's life claim per the table below.</p> <table border="1" data-bbox="349 205 669 409"> <thead> <tr> <th>Maximum Life Claim (hours to L₇₀)</th> <th>Test Duration (hours) *</th> </tr> </thead> <tbody> <tr> <td>30,000</td> <td>7,500</td> </tr> <tr> <td>35,000</td> <td>8,750</td> </tr> <tr> <td>40,000</td> <td>10,000</td> </tr> <tr> <td>45,000</td> <td>11,250</td> </tr> <tr> <td>50,000</td> <td>12,500</td> </tr> </tbody> </table> <p>* Prescribed test duration is the total ON time and shall not include the OFF time.</p>	Maximum Life Claim (hours to L ₇₀)	Test Duration (hours) *	30,000	7,500	35,000	8,750	40,000	10,000	45,000	11,250	50,000	12,500		<p>For color tunable lamps, the TM-21-11 projection for all LED sources used shall meet the requirement.</p> <p>Compliance with the above shall be documented with a TM-21 lumen maintenance life projection report as detailed in TM-21, section 7. The report shall be generated using data from the LM-80 test report for the employed LED package/module/array model ("device"), the forward drive current applied to each device, and the <i>in situ</i> TMP_{LED} temperature of the hottest device in the lamp. In addition to LM-80 reporting requirements, the following information shall be reported:</p> <ul style="list-style-type: none"> • Sampling method and sample size (per LM-80 section 4.3) • Test results for each T_S and drive current combination • Description of device including model number and whether device is an LED package, module or array (see Definitions) • ANSI target, and calculated CCT value(s) for each device in sample set • Δ u'v' chromaticity shift value on the CIE 1976 diagram for each device in sample set • A detailed rationale, with supporting data, for application of results to other devices (e.g., LED packages with other CCTs) <p>If units are tested both base-up and base-down, the average of surviving unit measured values shall be calculated for each orientation. If the difference between these averages is:</p> <ul style="list-style-type: none"> • Greater than 3%, the reported lumen maintenance shall be the lesser of the two averages rounded to the nearest tenth of a percent. • Less than 3%, the reported lumen maintenance shall be the average of all surviving units rounded to the nearest tenth of a percent. <p>If units are tested in one orientation, the average of surviving unit measured values shall be reported rounded to the nearest tenth percent.</p>
Maximum Life Claim (hours to L ₇₀)	Test Duration (hours) *														
30,000	7,500														
35,000	8,750														
40,000	10,000														
45,000	11,250														
50,000	12,500														

10.2. Rated Life: All Lamps

Lamp Type	ENERGY STAR Requirements	Methods of Measurement and/or Reference Documents	Supplemental Testing Guidance
Compact Fluorescent	<p>Lamp shall have a rated life ≥ 10,000 hours.</p> <p>At 40% of rated life 90% of the tested units shall be operational.</p> <p>≥ 50% of the tested units shall be operational at rated life.</p>	<p>See Section 10.1 Lumen Maintenance Requirements.</p>	<p>Sample Size: Same samples used for lumen maintenance testing, see Section 10.1.</p>
Solid-State	<p>Omnidirectional and decorative lamps shall have a rated life ≥ 15,000 hours.</p> <p>Directional lamps shall have a rated life ≥ 25,000 hours.</p> <p>All tested units shall be operational at all applicable lumen maintenance measurement points designated in Section 10.1.</p>		<p>For CFLs covered by DOE's regulatory program (i.e., medium base CFLs without reflectors or 3-way capabilities), the reported value shall be in accordance with 10 CFR 429.35.</p> <p>For lamps not covered by DOE's regulatory program, the reported value shall be the rated life in hours.</p>

10.3. Rapid Cycle Stress Test: Compact Fluorescent Lamps

Lamp Type	ENERGY STAR Requirements	Methods of Measurement and/or Reference Documents	Supplemental Testing Guidance
Compact Fluorescent	<p>Lamp, when cycled at 5 minutes on, 5 minutes off, shall survive the lesser number of cycles: one cycle per hour of rated life or 15,000 cycles. At least 5 units shall survive the minimum number of cycles.</p> <p>CFLs with a start time \leq 100 milliseconds, shall survive cycling once per every two hours of rated life, at 5 minutes on, 5 minutes off.</p>	<p>Measurement: (fluorescent not covered by DOE): IES LM-65-14 (clauses 4,5,6)</p> <p>Measurement (fluorescent covered by DOE): 10 CFR Part 430 Appendix W Subpart B</p>	<p>Sample Size: 6 units per model. The samples shall be unique for this test.</p> <p>For dimmable or multi-power lamps, testing shall be conducted at the highest wattage setting listed for the model.</p> <p>The reported value shall be the number of units surviving the minimum number of cycles.</p>

11. ELECTRICAL PERFORMANCE REQUIREMENTS

11.1. Electrical Safety: All Lamps

Lamp Type	ENERGY STAR Requirements	Methods of Measurement and/or Reference Documents	Supplemental Testing Guidance
All Lamps	Lamp shall comply with ANSI/UL 1993-2012 and ANSI/UL 8750-2009 as applicable.	Reference: ANSI/UL 1993-2012 ANSI/UL 8750-2009	Connected products must continue to comply with the applicable product safety standards – the addition of the functionality described in Section 12.7 Connected Product Criteria shall not override existing safety protections and functions.

11.2. Power Factor: All Lamps (Exemption: Lamps ≤ 5 Watts)

Lamp Type	ENERGY STAR Requirements	Methods of Measurement and/or Reference Documents	Supplemental Testing Guidance
Compact Fluorescent	Reported value for each lamp model shall have a reported value ≥ 0.5 .	Measurement: ANSI C82.77-10-2014 or U.S. Department of Energy Conservation Test Procedures for Compact Fluorescent Lamps (once final)	Sample Size: 10 units per model: 5 units tested base-up and 5 units tested base-down unless the manufacturer restricts specific use or position. If position is restricted, all units shall be tested in restricted position. Tested units, including low voltage lamps, shall be operated at rated voltage. The reported value shall be the average measured values of units tested rounded to the nearest tenth.
Solid-State	Omnidirectional lamps with rated/reported input power ≤ 10 watts shall have a reported value ≥ 0.6 . All other lamps shall have a reported value ≥ 0.7 .	Measurement: ANSI C82.77-10-2014 or U.S. Department of Energy Conservation Test Procedure for Integrated Light-Emitting Diode Lamps (once final)	

11.3. Frequency: All Lamps

Lamp Type	ENERGY STAR Requirements	Methods of Measurement and/or Reference Documents	Supplemental Testing Guidance
Compact Fluorescent	Lamp shall have a frequency within 20 to 33 kHz, or ≥ 40 kHz.		Sample Size: One unit per model. For purposes of third-party certification documentation shall not be reviewed when products are certified or during verification testing.
Solid-State	Lamp light output shall have a frequency ≥ 120 Hz.	Method of Measurement: None referenced Reference Document: IEEE Std 1789™-2015	Sample Size: One unit per model. Light output waveform shall be measured with a photodetector with a rise time of 10 microseconds or less, transimpedance amplifier and oscilloscope. Employed equipment models and method of measurement shall be documented. Temporal response, amplification and filtering characteristics of the system shall be suitably designed to capture the photometric waveform. Digitized photometric waveform data and an image of the relative photometric amplitude waveform shall be recorded. Measured data shall be recorded to a digital file with an interval between each measurement no greater than 0.00005 sec (50 microseconds) corresponding to an equipment measurement rate of no less than 20 kHz, and capture at least 1 second of data. For purposes of third-party certification documentation shall not be reviewed when products are certified or during verification testing.

11.4. Start Time: All Lamps

Lamp Type	ENERGY STAR Requirements	Methods of Measurement and/or Reference Documents	Supplemental Testing Guidance
Non-Connected Lamps	Reported value of time for lamp to remain continuously illuminated shall be within 750 milliseconds of application of electrical power.	Measurement: ENERGY STAR Start Time Test Measurement (fluorescent): U.S. Department of Energy Conservation Test Procedures for Compact Fluorescent Lamps (once final)	Sample Size: 3 units per model. The reported value shall be the average of measured unit values tested, rounded to the nearest millisecond.
Connected Lamps	Reported value of time for lamp to remain continuously illuminated shall be within 1 second of application of electrical power.		

11.5. Run-Up Time: All Compact Fluorescent Lamps (Exemption: LED Lamps)

Lamp Type	ENERGY STAR Requirements	Methods of Measurement and/or Reference Documents	Supplemental Testing Guidance
Compact Fluorescent	Reported value of time for lamp to achieve 80% stabilized light output shall be ≤ 45 seconds.	Measurement: ENERGY STAR Run-Up Time Test Reference Documents: IES LM-54-12	Sample Size: 10 units per model: 5 units tested base-up and 5 units tested base-down unless the manufacturer restricts specific use or position. If position is restricted, all units shall be tested in restricted position. Measurements shall be taken at the end of 100 hours of seasoning. The reported value shall be the average measured values of units tested, rounded to the nearest second.

11.6. Transient Protection: All Line Voltage Lamps (Exemption: Low Voltage Lamps)

Lamp Type	ENERGY STAR Requirements	Methods of Measurement and/or Reference Documents	Supplemental Testing Guidance
All Line Voltage Lamps	Lamp shall survive 7 strikes of a 100 kHz ring wave, 2.5 kV level. All units shall be fully operational at the completion of testing.	Measurement: ANSI/IEEE C62.41.2-2002, Category A Location.	Sample Size: 5 units per model. The sample shall be unique for this test.

11.7. Standby Power Consumption: All Lamps

Source Type	ENERGY STAR Requirements	Methods of Measurement and/or Reference Documents	Supplemental Testing Guidance
All Source Types	Lamps without integral controls shall not draw power in the off mode. Exception: Lamps with integral controls (e.g., motion sensors, photosensors, wireless control, standby mode, or connected functionality) shall consume no more than 0.5 watt in standby mode or network mode. Standby power (if applicable) shall be reported for equipment (outside of the lamp) required for connectivity (e.g., gateways, hubs, and network controllers, excluding equipment typically found in the home such as a Wi-Fi router).	IEC 62301 Edition 2.0 2011-01 Household electrical appliances - Measurement of standby power U.S. Department of Energy Conservation Test Procedures for Compact Fluorescent Lamps (once final) U.S. Department of Energy Conservation Test Procedure for Integrated Light-Emitting Diode Lamps (once final)	Laboratory test results shall detail off-state power consumption to the tenth of a watt. This applies to lamps that may have wireless controllability but may not meet all connected criteria as identified in the specification definition for connected lamp and Section 12.7 Connected Product Criteria . If required for connectivity, the lamp manufacturer shall specify one set of representative equipment (outside of the lamp) for which standby power shall be reported.

12. CONTROLS REQUIREMENTS: LAMPS EMPLOYING ANY CONTROL MECHANISM

12.1. Dimming Performance: All Lamps Marketed as Dimmable

Lamps designed for phase cut dimming operation (alterations to the line voltage to the lamp), shall be tested against all dimming performance requirements with a minimum of 5 dimmers from at least 2 different manufacturers. The lamp manufacturer shall specify and report the dimmers used for testing by the manufacturer name, model number and load ratings including current and wattage. EPA's intent is for the dimmers selected to be varied in electrical construction and to represent a wide range of potential consumer situations. For example, a selection of five dimmers might include at least one dimmer specified for use with energy efficient lighting (such as CFL or LED lamps), one that has pre-set levels, one forward-phase dimmer rated 600W, and one reverse-phase dimmer. As an alternative, a lamp designed to be compliant with NEMA SSL 7A may be tested against all dimming performance requirements with a corresponding NEMA SSL 7A compliant dimmer⁵. Lamp manufacturers of low voltage products shall specify and report the transformer(s) to be used for dimming testing by manufacturer name and model number.

Lamps compatible with a non-phase cut control device (e.g., a dimmer that does not alter the line voltage to the lamp, such as wireless controls), shall be tested with the control device(s) and application(s) specified by the partner against all dimming performance requirements. The lamp packaging and online product marketing materials shall call out the controls that can be used with the lamp. An asterisk or similar mark should appear next to the word "dimmable" and point to a statement similar to "only compatible with..." that indicates which dimmers the lamp is compatible with.

The tested minimum light level on dimmers or controls shall be the minimum light level claimed by the manufacturer (or 20% if no minimum is claimed), and the lamp shall meet audible noise requirements at this level. For purposes of third-party certification, maximum light output, minimum light output, flicker and noise levels shall be reported by the partner to the certification body. Partners may elect to provide the certification body with supporting test data and may request that this data be provided to EPA on their behalf. Review of supporting test data is not required for certification or for verification testing. However, EPA reserves the right to request this documentation at any time.

12.2. Maximum Light Output:

Lamp Type	ENERGY STAR Requirements	Methods of Measurement and/or Reference Documents	Supplemental Testing Guidance
All Lamps Marketed As Dimmable	Lamp light output on the maximum setting of a dimmer/control shall not fall below the lamp's baseline light output when operated without a dimmer by more than 20%. 80% of tested lamp/dimmer combinations must meet the requirement.	Measurement: ENERGY STAR Recommended Practice - Light Output on a Dimmer	Sample Size: 1 lamp per dimmer. See Section 8 of the Recommended Practice - Light Output on a Dimmer, for reporting information.

12.3. Minimum Light Output:

Lamp Type	ENERGY STAR Requirements	Methods of Measurement and/or Reference Documents	Supplemental Testing Guidance
All Lamps Marketed As Dimmable	Lamp light output on a dimmer/control shall be no more than 20% of the maximum light output of the lamp on each tested dimmer/control. 80% of tested lamp/dimmer combinations must meet the requirement.	Measurement: ENERGY STAR Recommended Practice - Light Output on a Dimmer	Sample Size: 1 lamp per dimmer. See Section 8 of the Recommended Practice - Light Output on a Dimmer, for reporting information.

⁵ The compatibility testing pathway of NEMA SSL 7A is available once the marketing guidelines for matching compliant lamps to compliant dimmer types have been set.

12.4. Flicker:

Lamp Type	ENERGY STAR Requirements	Methods of Measurement and/or Reference Documents	Supplemental Testing Guidance
All Lamps Marketed As Dimmable	Lamp average light output periodic frequency, highest percent flicker, and highest flicker index shall be reported.	Measurement: ENERGY STAR Recommended Practice - Light Source Flicker	Sample Size: 1 lamp per dimmer. See Section 8 of the Recommended Practice - Light Source Flicker, for reporting information.

12.5. Audible Noise:

Lamp Type	ENERGY STAR Requirements	Methods of Measurement and/or Reference Documents	Supplemental Testing Guidance
All Lamps Marketed as Dimmable	Lamp shall not emit noise above 24 dBA at 1 meter or less. 80% of tested lamp/dimmer combinations must meet the requirement.	Measurement: ENERGY STAR Test Method - Noise Reference: ISO 7574-4:1985, B.2.1 ANSI S12.55-2012/ISO3745:2012	Sample Size: 1 lamp per dimmer. Measurement shall be on a single lamp. See Section 8 of the Test Method – Noise, for reporting information. The baseline sound level may be corrected for in accordance with ISO 7574-4:1985, B.2.1. This allows for testing to be performed in chambers that are not fully anechoic. The reported sound level value shall be the loudest measurement of all lamp/dimmer combinations.

12.6. Products with Connected Functionality – Optional

Source Type	ENERGY STAR Requirements	Methods of Measurement and/or Reference Documents	Supplemental Testing Guidance
All source types	Product must continue to comply with the applicable product safety standards – the addition of the functionality shall not override existing safety protections and functions. Product must comply with Section 11.7 Standby Power Consumption. Power consumption (if applicable) shall be reported for equipment (outside of the lamp) required for connectivity (e.g., gateways, hubs, and network controllers, excluding equipment typically found in the home such as a Wi-Fi router).	Measurement: None	Test Requirements: Connected products without color tuning capabilities shall be tested at full power for all applicable requirements. Connected products with color tuning capabilities shall be tested under the conditions specified under Section 5.1 . Compliance with connected functionality requirements, in Sections 12.7-12.12, shall be demonstrated through examination of product and/or product documentation. If required for connectivity, the lamp manufacturer shall specify one set of representative equipment (outside of the lamp) for which power consumption shall be reported.

12.7. Connected Product Criteria:

To be recognized as connected, a “connected lamp” shall include elements (hardware and software or firmware) or instructions required to enable communication in response to consumer-authorized energy or performance related commands (e.g., instructions for downloading a mobile application, Bluetooth syncing guidance) and shall meet the requirements in Sections 12.8-12.12. These elements may reside inside or outside of the base lamp. For example, a “base lamp” may connect wirelessly via a home gateway or network controller to a cloud service that implements energy estimation functions.

The specific design and implementation of the connected lamp is at the manufacturer’s discretion provided it is interoperable with other devices via open communications protocol and enables economical, consumer-authorized third party access to the functionalities provided for in sections 12.9, 12.10 and 12.11. Capabilities of system controller and connected protocol shall be reported as applicable.

12.8. Open Access

The product shall enable connectivity by one of following means:

1. Open-standards communications from the lamp, or
2. Open-standards communications from an external controller, included with the product or available separately.
3. Where no suitable open standards communications method exists (e.g., an IP interface), an available and documented communication method must be used. In these cases, a manufacturer-specific method to implement the functions in sections 12.9, 12.10, and 12.11 shall be published for use with the product.

To enable interconnection with the product; an interface specification, Application Programming Interface (API) or similar documentation shall be made available to interested parties that enables sections 12.9, 12.10 and 12.11 connected functionality, and includes accuracy, units and measurement or estimation interval for Energy Consumption Reporting.

12.9. Energy Consumption Reporting

The lamp, or the gateway device or cloud service connected to it, shall be capable of interconnecting with consumer authorized entities to communicate data representative of its interval energy consumption. It is recommended that data be reported in watt-hours for intervals of 15 minutes; however, representative data may also be reported in alternate units and intervals as specified in the product manufacturer's interface specification or API. If the lamp does not provide power consumption directly in watts, the manufacturer shall make available a method for estimating power consumption, in watts, from the representative data that is provided by the lamp.

12.10. Operational Status Reporting

At a minimum, the lamp, or the gateway device or cloud service connected to it, shall be capable of providing the following information to energy management systems and other consumer authorized devices, services or applications via a communication link: operational status (e.g., on/off).

12.11. Remote Management

The product shall be capable of receiving and responding to energy management system or other consumer authorized remote requests, via devices, services or applications, similar to hard-wired consumer controllable functions.

12.12. Information to Consumers

If additional devices, services, and/or infrastructure are required to activate the product's connected capabilities, prominent labels, or other forms of consumer notifications shall be displayed at the point of purchase and in the product literature. (e.g., "This product has Z-wave control capability and requires interconnection with a Z-wave controller to enable local lighting control.")

13. LAMP TOXICS REDUCTION

13.1. Lamp Toxics Reduction: All Lamps

Lamp Type	ENERGY STAR Requirements	Method of Compliance
All Lamps	<p>Lamps \leq 23.0 rated watts shall contain \leq 2.5 milligrams (mg) mercury per lamp.</p> <p>Lamps $>$ 23.0 rated watts shall contain \leq 3.0 milligrams (mg) mercury per lamp.</p> <p>When present, lamp shall contain restricted levels of the following materials, where the maximum concentration values allowed by weight in homogeneous materials are:</p> <ul style="list-style-type: none"> • Lead: 0.1% • Cadmium: 0.01% • Hexavalent chromium: 0.1% • Polybrominated biphenyls (PBB): 0.1% • Polybrominated diphenyl ethers (PBDE): 0.1% <p><u>Exemptions:</u></p> <ol style="list-style-type: none"> 1. Copper alloy containing up to 4% lead by weight 2. Lead in high melting temperature type solders (i.e. lead-based alloys containing 85% by weight or more lead) 3. Electrical and electronic components containing lead in a glass or ceramic other than dielectric ceramic in capacitors, e.g., piezoelectronic devices, or in a glass or ceramic matrix compound 4. Lead in dielectric ceramic in capacitors 5. Lead in white glasses used for optical applications 6. Lead in solders to complete a viable electrical connection between semiconductor die and carrier within integrated circuit flip chip packages 7. Lead in glass of cathode ray tubes, electronic components and fluorescent tubes 8. Cadmium and its compounds in electrical contacts 9. Cadmium in color-converting II-IV LEDs ($<$ 10 μg Cd per mm² of light-emitting area) for use in solid state illumination or display systems 10. Lead as an alloying element in aluminum containing up to 0.4% lead by weight 11. Lead and cadmium in printing inks for the application of enamels on glasses, such as borosilicate and soda lime glasses 	<p>For purposes of third-party certification, lamp toxics documentation shall not be reviewed when products are initially certified or during verification testing. Instead manufacturer shall maintain documentation on file to demonstrate that certified products meet these requirements. EPA reserves the right to request this documentation at any time. For the purposes of documenting mercury content, the following test procedure shall be used: IEC 62554 Ed 1.0 Sample Preparation for Measurement of Mercury Level in Fluorescent Lamps (2011-08-19).</p> <p>For materials other than mercury, manufacturer may rely on component suppliers to provide certification or declaration documents to show that homogenous materials used in lamps comply with the requirement. Alternatively, manufacturer may have lamp components tested in accordance with IEC 62321 or other appropriate analytical technique to verify that homogenous materials do not exceed the concentration limits of the six regulated substances. Handheld XRF analyzers/scanners may also be used to verify compliance.</p>

14. DIMENSIONAL REQUIREMENTS

14.1. Lamp Shape Dimensions: All ANSI Standard Lamps and GU-24 base Solid-state Lamps

(Exemption: Non-Standard Lamps)

Lamp Type	ENERGY STAR Requirements	Methods of Measurement and/or Reference Documents	Supplemental Testing Guidance
Omnidirectional ANSI Standard Lamps	Lamp shall comply with ANSI minimum overall length (min OAL), maximum overall length (MOL) and maximum lamp diameter values, where they exist.	Reference Documents: ANSI C78.20:2003 ANSI C78.23:1995 (R2003)	Sample Size: One unit per model. GU24 base lamps may qualify as an allowable variation of an ANSI standard lamp, and shall meet the min OAL and MOL of the ANSI standard lamp.
Directional ANSI Standard Lamps	Lamp shall comply with ANSI minimum overall length (min OAL), maximum overall length (MOL) and maximum lamp diameter values, where they exist.	Reference Documents: ANSI C78.21-2011 ANSI C78.50-2014 ANSI C78.79-2014	A +5% tolerance may be applied to the measured maximum overall length (MOL) of an omnidirectional lamp if the lamp fails to meet the requirement without the tolerance.
Decorative ANSI Standard Lamps	Lamp shall comply with ANSI minimum overall length (min OAL), maximum overall length (MOL) and maximum lamp diameter values, where they exist. Where no ANSI maximum lamp space drawing exists, lamp maximum outside diameter shall be within $\pm 15\%$ of the lamp nominal diameter. Globe lamps should be essentially spherical and have a ratio of the maximum overall diameter to maximum overall length (excluding base/cap length per ANSI C81.61) of greater than 0.80.	Reference Documents: ANSI C78.23:1995 (R2003)	

15. LAMP LABELING, PACKAGING & WARRANTY REQUIREMENTS

15.1. Lamp Labeling: All Lamps

Lamp Type	ENERGY STAR Requirement
All Lamps	<p>Each of the following shall be printed on the lamp:</p> <ul style="list-style-type: none"> ENERGY STAR partner, lamp manufacturer or brand name Lamp model or retail SKU number consistent with model number or identifying information in the ENERGY STAR listing of certified models Lamp nominal correlated color temperature including "Kelvin" or "K"* Rated wattage in watts (lamps not covered by FTC requirements)* For lamps not covered by FTC requirements, lamp rated lumen output in lumens or lamp nominal beam angle in degrees for applicable products (i.e., MR, MRX). <p>*The lamp correlated color temperature and wattage may be included in the lamp model number and must use "K" or "W" after each respective number.</p>

15.2. Lamp Packaging: All Lamps except as Noted⁶

Criteria	ENERGY STAR Requirement
General	Packaging and marketing claims shall represent the product consistent with its certification.
Model Number	Lamp packaging shall include model number or retail SKU number consistent with model number or identifying information in the ENERGY STAR listing of certified models.
Controls Compatibility	<p>Lamp packaging exterior shall display on the front panel in ≥ 8 point type an indication of the lamp's dimming capability: "dimmable", "for dimmers", "non-dimmable", "do not use with dimmers" or the like. Dimmable lamp packaging shall indicate that the lamp may not be compatible with all dimmers, and shall reference a website providing regularly updated dimmer compatibility information for the lamp model. Lamps that are dimmable with a limited set of controls, e.g., designed for non-phase cut dimmers, that elect to test and list compatibility with the limited set of controls must list all compatible controls on packaging. Lamps that use the SSL7A compatibility testing must use the labeling guidelines for SSL7A complaint products. See Section 12: Dimming.</p> <p>Packaging for lamps not designed for operation with photosensors, motion sensors or timing devices shall indicate in ≥ 8 point type "not compatible with photosensors", "not compatible with timers", "not compatible with motion sensors", "not compatible with photosensors, motion sensors, or timers", or the like.</p>
Application Exceptions	<p>Lamp packaging exterior shall clearly state specific application restrictions (e.g., totally enclosed luminaires, recessed luminaires, insulated ceiling air-tight (ICAT) recessed downlights, damp locations) that would compromise the performance of the lamp and could result in a lamp's noncompliance with the ENERGY STAR specification performance requirements. All application exceptions that appear on the lamp shall also be listed on the lamp package exterior. (≥ 8 point type and/or bold text is recommended.)</p> <p>LED MR Lamps Intended for use on Low-Voltage Circuits: Lamp package must state compatibility with low-voltage transformers. Lamp package and product information sheet must include a caution label indicating the lamp may not be compatible with all low-voltage transformers used in existing light fixtures and identifying the Web address (URL) to find up-to-date low-voltage transformer compatibility and appropriate use information. A voltage waveform (AC or DC) for which a low voltage MR lamp does not provide the certified performance shall be considered an application exception which shall be detailed on lamp packaging: "Not intended for AC operation." or "Not intended for operation on AC transformers." or "Not for use with AC transformers." or the like, where "DC" may be substituted for "AC", as applicable.</p>
Restricted Position	If lamp is tested in a limited orientation, lamp packaging shall indicate the performance ratings are based on that orientation as applicable (e.g., base up only).
Minimum Starting/Operating Temperature	Lamp packaging shall state the minimum starting or operating ambient temperature and shall state any other conditions required for reliable starting as designated by the partner.
Warranty	Lamp packaging shall include warranty information see Warranty Requirements Section of this specification.
CCT Descriptor	<p>If packaging includes a color descriptor term, EPA recommends the following corresponding nomenclature as outlined below.</p> <ul style="list-style-type: none"> • 2200K – Amber White • 2500K – Sunrise/Sunset White • 2700K – Soft White • 3000K – Warm White • 3500K – Neutral White • 4000/4100K – Cool White • 5000K – Daylight • 6500K – Daylight

⁶ Packaging requirements must appear on the exterior of lamp packaging and except for model number and retail SKU number, packaging requirements may not be on the bottom of lamp packaging. The outermost package of bulk packaged (e.g. multi-packs for retail or commercial sales) lamps facing the intended end user shall meet these requirements.

15.3. Warranty: All Lamps

Criteria	ENERGY STAR Requirement									
Warranty	<p>Per the table below lamps shall be backed by a minimum warranty corresponding to the lamp life rating and based on continuous operation over the corresponding number of hours per day.</p> <table border="1" data-bbox="337 331 966 457"> <thead> <tr> <th data-bbox="337 331 560 401">Lamp Life Rating (Hours)</th> <th data-bbox="560 331 810 401">Minimum Warranty (Years From Date of Purchase)</th> <th data-bbox="810 331 966 401">Hours of Use Per Day</th> </tr> </thead> <tbody> <tr> <td data-bbox="337 401 560 430">< 15,000</td> <td data-bbox="560 401 810 430">2</td> <td data-bbox="810 401 966 430">3</td> </tr> <tr> <td data-bbox="337 430 560 457">≥ 15,000</td> <td data-bbox="560 430 810 457">3</td> <td data-bbox="810 430 966 457">3</td> </tr> </tbody> </table> <p>Lamp packaging exterior shall state "Warranty" or "Limited Warranty" and the warranty period (in years) per the above table, and provide a phone number or website address for consumer complaint resolution.</p> <p>If the complete written warranty is not included within the lamp packaging, it shall be available at a website address provided on the packaging exterior.</p>	Lamp Life Rating (Hours)	Minimum Warranty (Years From Date of Purchase)	Hours of Use Per Day	< 15,000	2	3	≥ 15,000	3	3
Lamp Life Rating (Hours)	Minimum Warranty (Years From Date of Purchase)	Hours of Use Per Day								
< 15,000	2	3								
≥ 15,000	3	3								

END OF SPECIFICATION

APPENDIX A-1: LUMINOUS INTENSITY DISTRIBUTION DIAGRAM FOR OMNIDIRECTIONAL LAMP

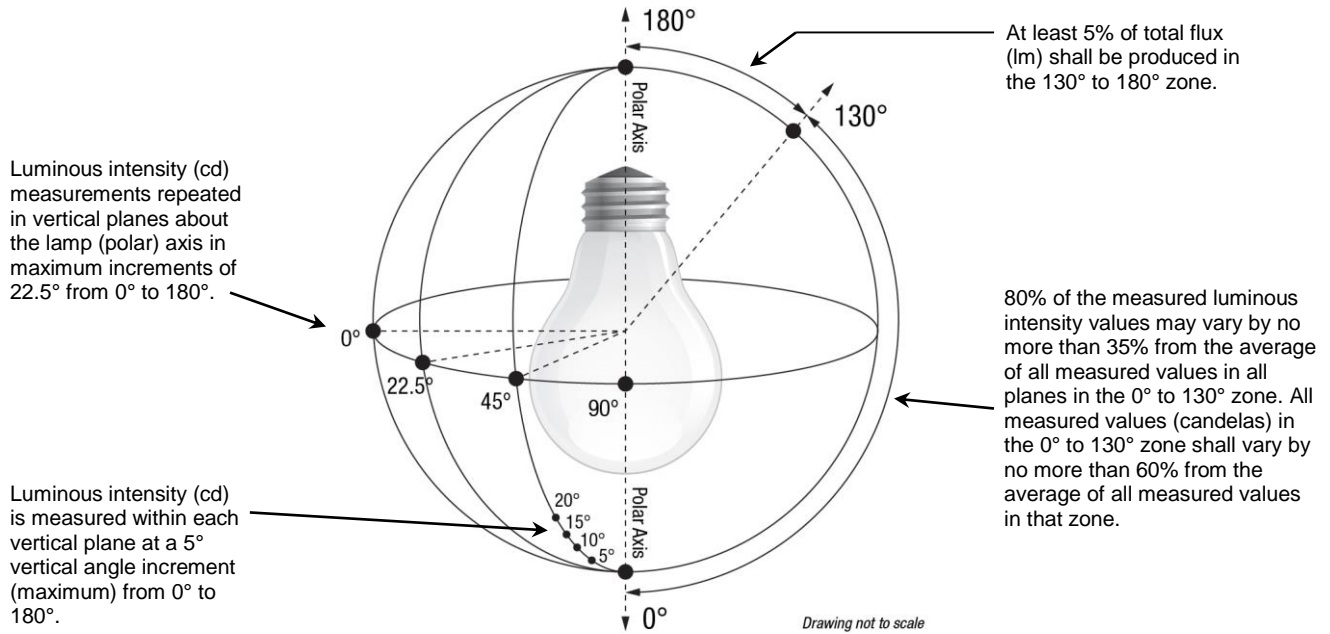

APPENDIX A-2: LUMINOUS INTENSITY DISTRIBUTION DIAGRAM FOR DECORATIVE LAMP

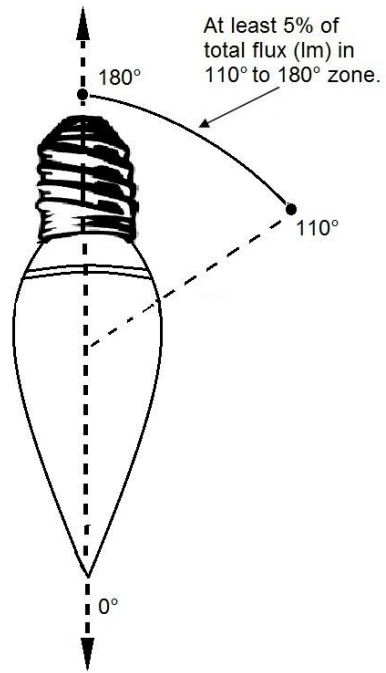

Drawing not to scale

APPENDIX B: CERTIFICATION MILESTONES FOR RATED LIFE TESTING

Example Milestones for Rated Lifetime/Lumen Maintenance			
Lifetime Rating	1 st (Early Interim) Certification Milestone ¹	2nd (Interim) Certification Milestone ²	Full Lifetime Certification
CFL - 10,000 Hrs.	4,000 Hrs. (40% of Life)	-	10,000 Hrs. (100% of Life) ³
CFL - 12,000 Hrs.	4,800 Hrs. (40% of Life)	-	12,000 Hrs. (100% of Life) ³
CFL - 15,000 Hrs.	6,000 Hrs. (40% of Life)	-	15,000 Hrs. (100% of Life) ³
LED - 15,000 Hrs.	3,000 Hrs.	6,000 Hrs.	
LED - 20,000 Hrs.	3,000 Hrs.	6,000 Hrs.	
LED - 25,000 Hrs.	3,000 Hrs.	6,000 Hrs.	
LED - 30,000 Hrs.	-	6,000 Hrs.	7,500 Hrs.
LED - 35,000 Hrs.	-	6,000 Hrs.	8,750 Hrs.
LED - 40,000 Hrs.	-	6,000 Hrs.	10,000 Hrs.
LED - 45,000 Hrs.	-	6,000 Hrs.	11,250 Hrs.
LED - 50,000 Hrs.	-	6,000 Hrs.	12,500 Hrs.

¹ 100% of solid-state lamps and 90% of compact fluorescent must be operational

² 100% of solid-state lamps must be operational

³ 50% of compact fluorescent lamps must be operational